

**aeros<sup>®</sup>**

Serving the suction therapy needs of healthcare

**instavac<sup>®</sup>**  
**aspirator**

**Reprocessing Maintenance  
and Service Manual**

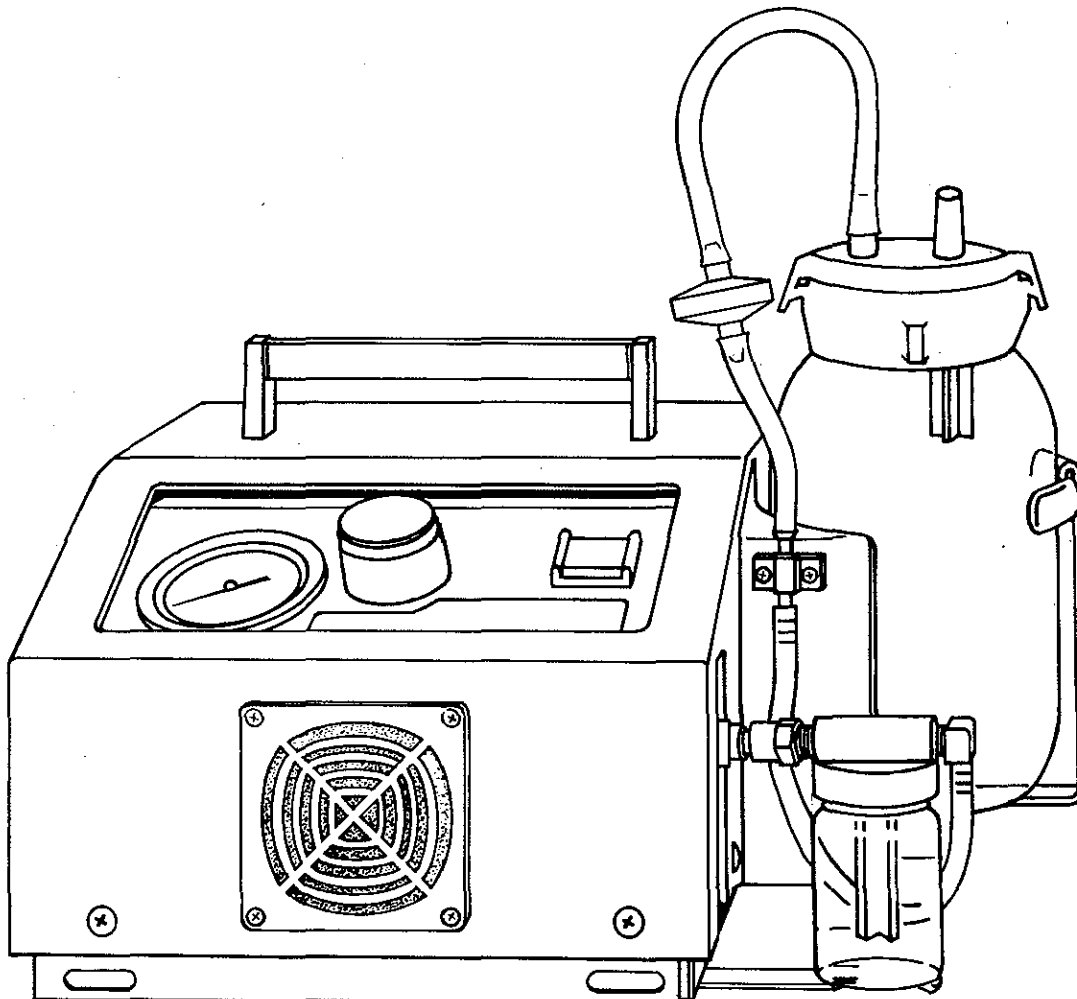

---

## Introduction

Your **Aeros Instavac**® Aspirator is designed to provide years of trouble-free operation if properly maintained. This manual will provide you with all the between patient cleaning and preventative maintenance procedures required to keep the unit operating efficiently.

The heart of the **Aeros Instavac** is its carbon vaned, rotary vane pump. This high performance vacuum pump is permanently lubricated and since it requires no oiling, the unit can be completely enclosed. This allows us to incorporate the second key operating feature — extended runs without heat gain. The unique fan driven cooling systems takes advantage of the air tight enclosure to pull air across the pump, dissipating heat so your **Instavac** can

run all day — day after day. These features address the growing demands of modern health care for high performance, low maintenance equipment.

Proper care of your new **Instavac** is very simple. The between patient cleaning procedure involves five simple steps requiring no tools. The semi-annual preventative maintenance procedure is clearly outlined in this manual. It should be performed by a qualified bio-medical technician and should not take longer than 20 minutes.

From time to time small design changes are made in components or assemblies. If your unit varies from this manual, note the serial number and call the factory at 1-800-662-5822.

---

## Specifications

LISTINGS:	U.L. 544U, FDA listed and inspected
ELECTRICAL REQUIREMENTS:	120 V, 1 Phase, 60 Hz.
AMP DRAW:	1.9 running amps.
SOUND LEVEL:	46 dBA (Test equipment one meter from unit).
STATIC VACUUM LEVEL:	560mm mercury maximum (22 inches mercury)
ADJUSTABLE VACUUM RANGE:	Calibrated from zero to 12" Hg or 300 mm Hg on gauge. Maximum vacuum, 22 inches Hg at "Full Vac" setting.
FREE AIR FLOW:	31 liters per minute minimum.
PUMP-DOWN TIME:	Evacuate 1300 cc collection canister in less than 2 seconds.
VACUUM PUMP:	Continuous duty carbon vane rotary (No lubrication required).
CURRENT LEAKAGE:	Normal operation worst case 22ua Per UL File #E58692.
DIELECTRIC TEST:	Tested at 1240V for 60 seconds; No Breakdown.
FUSES:	Two 3 Amp Slo-Blow fuses provided (Power and neutral)
WEIGHT:	19.77 lbs (sans collection canister)
DIMENSIONS:	13 inches wide (sans collection canister) 11 inches deep (sans exhaust filter) 8 inches high (with handle)

---

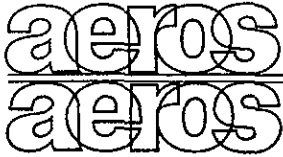

AEROS INSTRUMENTS, INC.

3411 Commercial Avenue  
Northbrook, Illinois 60062  
Telephone (312) 564-8020

**SUBJECT: OSHA HAZARD COMMUNICATION STANDARD**  
29 CFR Section 1910.1200 et seq,  
and States Right-To-Know Laws

Dear Aeros Customer:

You have purchased one of the most reliable air moving devices in the industry—an Aeros pump. Aeros wants you to be pleased with the performance of your unit and we will back it up with the finest warranty and service available.

Because of the above-cited regulation and law, it has come to our attention that many of our customers utilize our pumps in processes which contaminate the pumps with either radioactive, biological, toxic and hazardous chemical substances. Our facilities do not have the ability to know what hazardous substances are present in a pump returned for service. Moreover, our facilities often do not have the protective equipment and means necessary to safely repair these pumps when they are returned for service.

Accordingly, if a unit has been contaminated with radiological, biological or toxic substances, we cannot accept it for service at any of our facilities. If the unit has been contaminated with or contains a hazardous chemical (as defined in the OSHA Hazard Communication Standard), we may or may not be able to accept the unit for repair depending on the particular hazardous chemical. In this regard, if you have a unit needing repair which has been contaminated with or contains a hazardous chemical, you must first call our Service Department at (800) 662-5822 and inform our personnel of the hazardous chemical involved and those steps necessary for our employees to protect themselves while repairing the unit. If we have the necessary facilities and protective equipment available, only then will we accept the unit for service.

If a unit is shipped to us for repair under these guidelines, it is important that you comply with the OSHA Hazard Communication Standard by supplying a Material Safety Data Sheet and appropriate labeling for any hazardous chemical contaminating or contained in a pump returned to us for service.

If there are any questions regarding serviceability, please call our Service Department (800)662-5822.

Thank you for your cooperation.

AEROS INSTRUMENTS, INC.

P/N 1513001

# aeros

Serving the suction therapy needs of healthcare

## instavac<sup>®</sup>

# MODEL 2500ASY SET-UP and ASSEMBLY INSTRUCTIONS

### 1. Remove the Instavac from the carton and place it on a clean working surface.

**NOTE:** After unpacking the unit from the shipping carton, examine carefully for damage. If damage is apparent, notify the transportation company to file a claim. Save all shipping containers and packing for the transportation company representative.

### 2. Install the Collection Jar:

- Loosen the 7/16" hex nut on the bottom of the unit to extend the canister bracket.
- Place the 1300 CC Jar provided (or any collection canister), in the bracket.
- Push the bracket in for a snug fit and tighten the hex nut.
- Several "reprocessing kits" are included. Follow the instructions in the kit for proper fit and tubing connections.

### 3. Install bacterial filter on exhaust port located on the back of the machine.

**YOUR INSTAVAC ASPIRATOR IS NOW READY FOR USE.**

#### PACKAGE CONTENTS:

- Unit
- Bacterial Filter
- Collection Canister with Cap Bracket
- 3 samples of turn around kit #2311

#### DOCUMENTATION

- Owner Registration/Warranty Card
- Central Supply Envelope
- Bio Medical Envelope

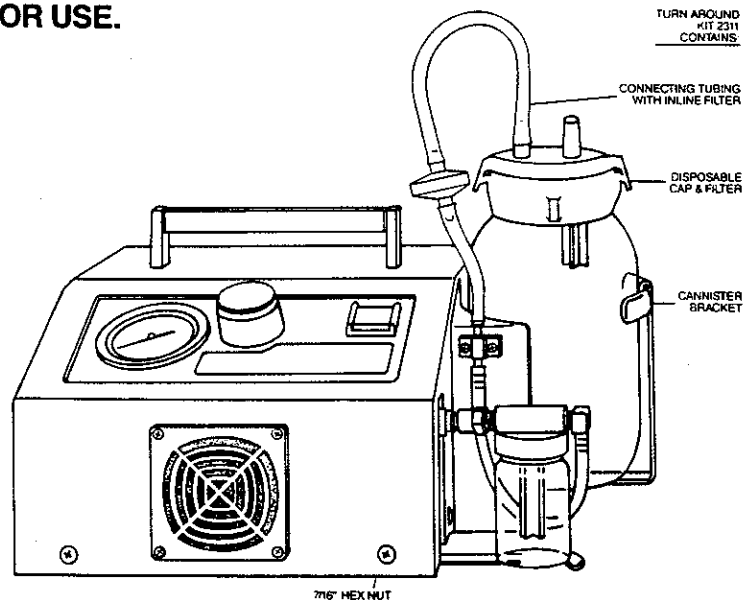

# aeros<sup>®</sup> Instruments, Inc.

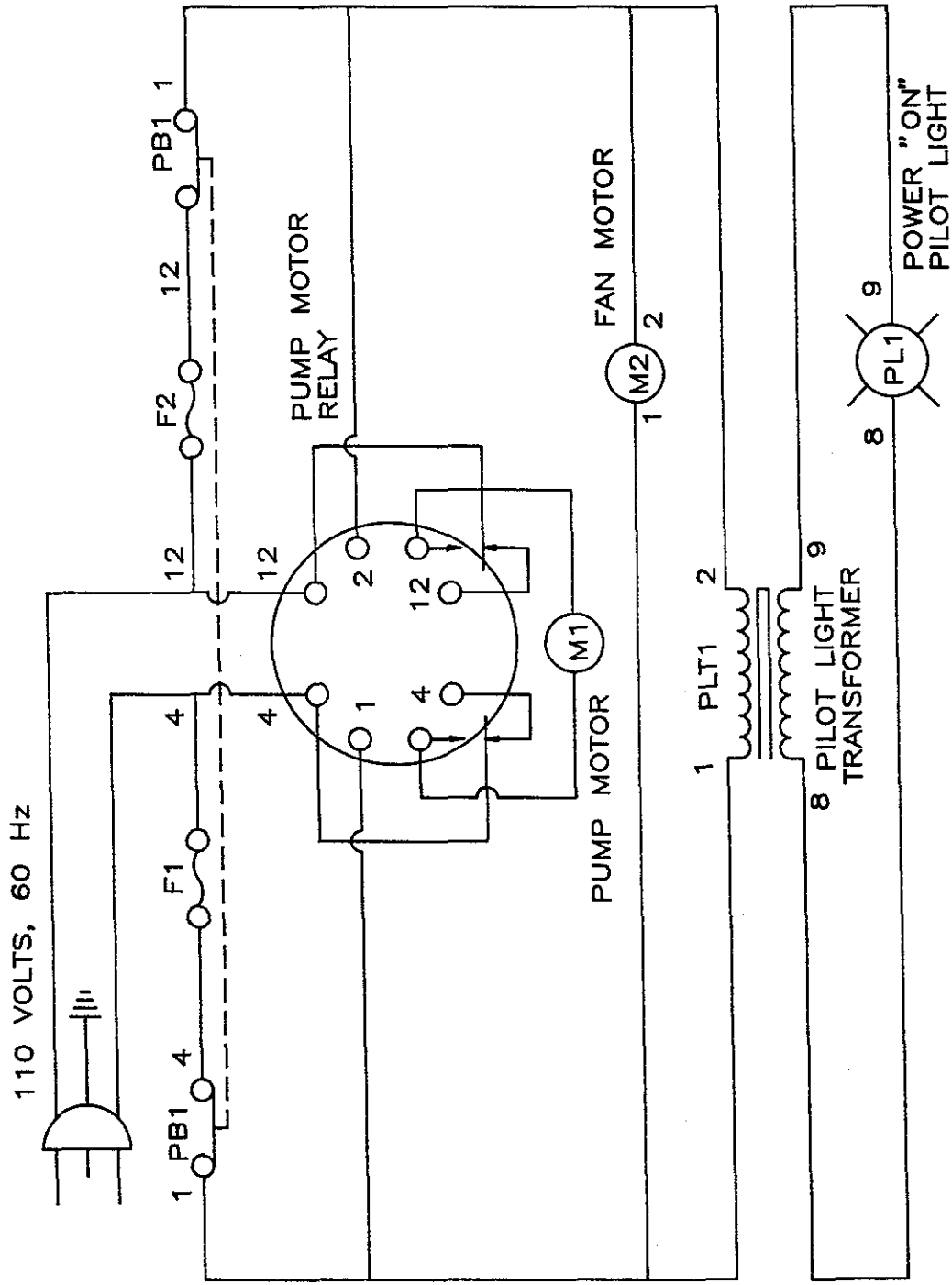

- NOTES:
1. WIRES #12 ARE WHITE 18 AWG.
  2. WIRES 8 & 9 ARE 22-18 AWG.
  3. ALL OTHER WIRES ARE BLACK 18 AWG.



erving the suction therapy needs of healthcare

**ATTENTION: BIOMEDICAL ENGINEERING DEPARTMENT**

The enclosed Reprocessing Maintenance and Service manual will provide you with the necessary information to maintain your new portable suction equipment.

Please review the manual, especially the section on the preventative maintenance procedure. A sample Preventative Maintenance kit is attached for your use during the warranty period.

We appreciate your selection of Aeros equipment and encourage your suggestions and inquiries regarding its use. Our customer service personnel will be glad to answer any questions you or your staff may have.

We are here to serve you. Call us at 1-800-MOBLVAC or 1-312/564-8020.

**AEROS INSTRUMENTS, INC.**

# Between-Patient Cleaning and Reprocessing

The following procedures should be performed after each patient use to reduce the possibility of cross-contamination; and assure proper continued operation.

## A. Wipe Down and General Cleaning

The **Aeros Instavac** Aspirator cover can be cleaned as often as necessary, using a damp cloth and a mild disinfectant detergent. Care should be taken to avoid excessive moisture near the control panel.

## B. Replace the Bacterial Filter

Gently twist and pull the filter off the rubber mount, located on the rear of the unit. Replace it with **Aeros** part #5576 or any standard disposable 1/2 micron anesthesia breathing circuit filter.

## C. Clean Air Inlet Filter

The air inlet filter pad can be vacuumed or brushed when necessary. To remove the air intake filter, simply snap out the "grate" with a finger nail or a pencil. If build-up is excessive, the filter should be removed and hand washed in mild detergent; then thoroughly rinsed in water. Replace the filter with **Aeros** part #5683 if build-up cannot be removed.

## D. Examine the Sump Loop Tubing and the Safety Overflow Trap

If fluids or particles have collected in the glass jar or the tubing, follow the overflow clean up procedure.

## E. Install New Connecting Tubing and Collector Canister

If the reusable **Aeros** glass collection system is used, Part #2311ASY is a kit containing a disposable cap & float assembly kit plus connecting tube with an in-line filter to facilitate returning the **Instavac** to service promptly.

## Overflow Clean Up Procedure (Kit # 2560 ASY Recommended)

1. To remove the safety overflow trap from the unit, pull down on the sump loop tubing attached to the bottom of the vacuum inlet connector. Gently push the trap towards the unit to relieve any pressure on the quick release fitting. Press the retaining ring against the fitting while firmly pulling the trap assembly away from the unit (A 5/16" open end wrench may be used instead of your fingers).
2. Unscrew the cap from the jar. Empty the jar and clean the components as required, (Kit #2560ASY contains a new float and the necessary tubing). Reassemble the trap. Take note that the float is in the down position and the cap is tight to ensure an airtight seal.
3. Reconnect the tubing to the safety overflow trap. Push the trap back into its original position, pull back gently on the assembly to be sure the connector has snapped securely in place.
4. Test run the unit to assure proper re-assembly.

Kit 2311ASY contains:

- Connecting tubing with filter
- Disposable cap and float

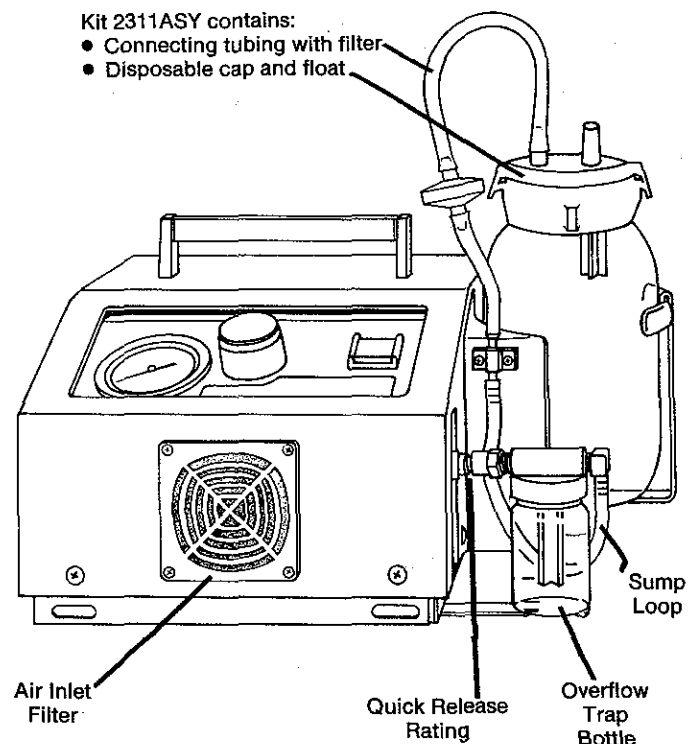

# Preventative Maintenance

Past experience has shown that years of trouble-free operation are possible if this simple preventative maintenance procedure is performed. Frequency of this procedure is a function of use and proper between-patient cleaning and reprocessing. The factory recommendation is every 6 months, but this may be extended as experience dictates. Under no circumstances should the interval exceed one year. This procedure should be performed by a qualified technician and a service diary is recommended. Although the flushing solution is non-flammable, it is advised that this procedure be performed in a well ventilated area, and disposed of properly.

## Requirements:

- Electrical outlet
- Flushing solution #5725
- **Aeros Instavac** P.M. Kit #2561ASY
- Philip's head screwdriver
- 5/16 O.E. wrench
- 7/16 O.E. wrench
- ¼" tubing, 6" and 12" long
- **Vac-U-Test** or other vacuum measurement device

### 1. Remove safety overflow trap assembly.

- Pull down on the sump loop tube to free it from the vacuum inlet fitting.
- With pressure against the retaining ring (a 5/16 O.E. wrench works well) the assembly should slide off the male fitting.

### 2. Clean the safety overflow trap assembly.

- Unscrew the bottle from the assembly.
- Remove the sump loop tube (if clean it may be used for Step 6).
- Discard the gasket and float assembly.
- Wash the jar and the cap assembly thoroughly and let dry.

WITH THE UNIT UNPLUGGED FROM THE ELECTRICAL OUTLET.

### 3. Remove the shroud.

- Remove all seven (7) P.H. screws (2 in front, 1 on right side and 4 in the rear).

- Lift the shroud straight up. Note: the rear panel of the unit folds back.

### 4. Remove the exhaust assembly.

- Unscrew the 8/32 nut to free the assembly from its bracket.
- Rotate the brass pipe out to allow the assembly to be pulled straight off.
- With pressure against the retaining ring (a 5/16 O.E. wrench works well) the assembly should slide off the long brass exhaust tube.

### 5. Clean the exhaust assembly.

- Discard the 6" piece of clear tubing.
- Unscrew the jar and wash thoroughly.
- With a 7/16" wrench remove the felt filters (2) and replace with new.

*Note:* If the carbon powder build-up is excessive, the P.M. frequency should be increased.

- Reassemble the assembly but do not reinstall at this time.

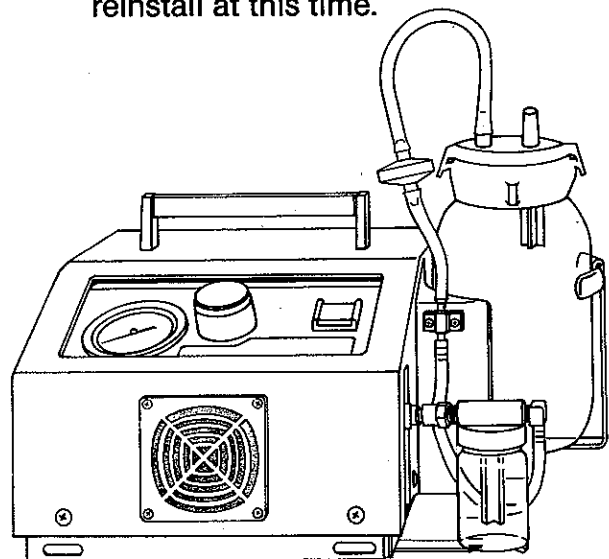

Overflow Trap  
Bottle Assembly

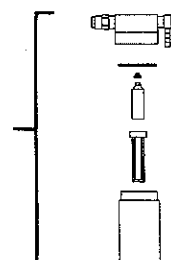



## 6. Flush the pump.

- Attach approximately 6" of standard 1/4" tubing to the male fitting exposed by the removal of the overflow trap assembly.
- Securely attach a 12" piece of 1/4" tubing to the brass tube exposed by the removal of the exhaust assembly. Place the other end of this tube in a suitable container to catch the flushing solution which will come out as a spray. (A waste basket works well.)
- Rotate the vacuum regulator knob all the way counter clockwise to get "full vacuum."
- Fill the overflow trap bottle with the 5725 flushing solution.

## PLUG THE UNIT INTO THE ELECTRICAL OUTLET.

- Turn the unit "on" and, by placing the tube on the inlet fitting, into the solution draw the solution through the pump.
- If the exhaust was not clear, or if there was excessive carbon found in the exhaust assembly during the filter change, repeat the flush with fresh solution.
- Let the unit run a few seconds to completely exhaust all of the solution.
- Dispose of waste liquid by allowing to evaporate, or in a closed container and placed in refuse.

## UNPLUG THE UNIT FROM THE ELECTRICAL OUTLET.

## 7. Install new gauge filter.

- Gently pull the fitting from the back of the gauge assembly. Remove the clear tubing and replace the "donut" gauge filter.

## 8. Replace the exhaust assembly.

- Insert the tube into the elbow and push it on firmly. Be sure it is locked on by pulling back.
- Position the assembly under the bracket and replace the 8/32 nut.
- Install the new 6" piece of silastic tubing (push completely onto both fittings).

## 9. Replace the shroud.

- Do not replace the 7 screws until the unit has been functionally verified.

## 10. Replace the safety overflow trap assembly.

- Use the new gasket, float, cage and sump loop tube found in the P.M. kit.
- Be sure that the jar is tight and that the float is at the bottom of the cage.

## 11. Replace the air inlet filter pad.

- "Snap" out the grate on the air inlet filter and replace the pad. Push on all 4 corners to be sure the grate is locked on.

## 12. Functional verification.

- Connect a tube from the vacuum inlet fitting to the **Aeros Vac-U-Test** in its bench mount configuration or any other vacuum measurement instruments.

## PLUG THE UNIT INTO AN ELECTRICAL OUTLET.

- Refer to the performance specifications on page one.

## 13. Secure shroud.

- Install all 7 P.H. screws to secure the shroud.
- A punch may help "line up" Tinnerman nuts.

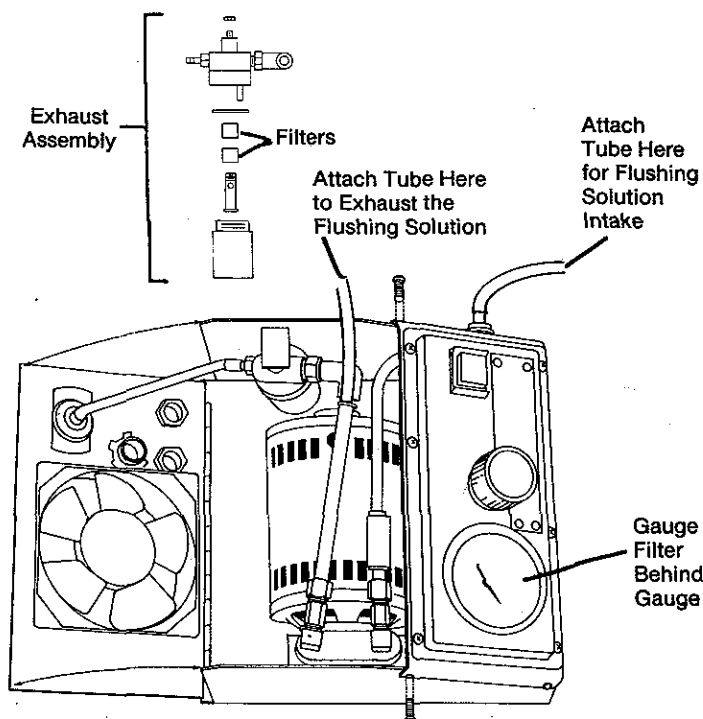

# Service

**CAUTION:** Electrical shock hazard. Turn unit off and disconnect power cord plug from electrical outlet before performing any of the following procedures.

## A. Switch Bulb Removal

1. Firmly pull the switch cover straight up and off the switch.
2. Grasp the two metal clips on each side of the bulb, gently squeeze them towards the bulb while lifting the assembly out of the switch.
3. Replace the bulb.
4. Push the holder back into the switch and replace the cover.

## B. Switch Removal

### [PRIOR SHROUD REMOVAL HELPFUL]

1. Remove the switch cover and bulb as described in Step A of this section.
2. With a small screwdriver, turn the screws inside the housing counterclockwise until the switch can be removed from the front of the panel.
3. Carefully pull the switch through the front of the control panel.
4. With a pair of needle nose pliers gently grip the wire lugs and pull them off the switch terminals.
5. Replace the switch in the reverse order, making certain all wires are returned to their proper location per the diagram accompanying the new switch.

## C. Regulator Knob and Stem Removal [PRIOR SHROUD REMOVAL REQUIRED]

1. Increase the regulator knob until it stops, then turn it back a half turn.
2. Lift off the gauge lens cover, disconnect the fitting on the back of the gauge and push the gauge out the front to remove it.

3. While pressing down on the control panel between the gauge and the regulator knob, insert a 5/64" ball end allen wrench into the set screw in the body of the regulator until the knob and stem can be unscrewed from the body.
4. Insert the new knob and stem assembly and turn it down about half way into the regulator body. (Threads and o-rings are factory lubricated and ready for installation.)
5. Tighten the set screw until it stops, then back it off approximately 1/8 turn to prevent any scoring of the shank.
6. Replace gauge and lens.

## D. Gauge Removal

### [PRIOR SHROUD REMOVAL REQUIRED]

1. Place a small screwdriver under the edge of the lens and gently pry it up from the panel surface.
2. Slide the plastic gauge connector off the back of the gauge.
3. Raise the gauge out of the housing by pushing up on the gauge from underneath the housing and gripping the edges of the gauge as it protrudes from the housing.
4. Reassemble the gauge in reverse order.
5. Verify visually that the filter is seated flat.

## E. Fan & Transformer and Relay Removal

### [PRIOR SHROUD REMOVAL REQUIRED]

1. All are easily removed by disconnecting the wires and removing the mounting hardware. (Please make note of wire placement to assure proper replacements.)

## F. Pump Removal [PRIOR SHROUD REMOVAL REQUIRED]

1. Disconnect the Exhaust Assembly from the pump tubing.
2. Disconnect the fitting from the brass tubing on the intake side of the pump. (DO NOT DISASSEMBLE THE CHECK VALVE ON THE INTAKE SIDE OF THE PUMP AS THIS MAY AFFECT THE SAFE OPERATION OF THE UNIT.)
3. Disconnect the pump electrical wires from the terminal back.

4. Remove the mounting hardware from the feet of the pump and lift the assembly out of the unit.

**NOTE:** The pump should not be serviced by any institution other than the factory. Any service of the pump performed outside the factory will void the warranty. When ordering a new pump assembly, include the serial number of the Instavac in which it is to be installed to assure proper replacement fittings.

Remove Screws  
to Tip Control  
Panel Forward

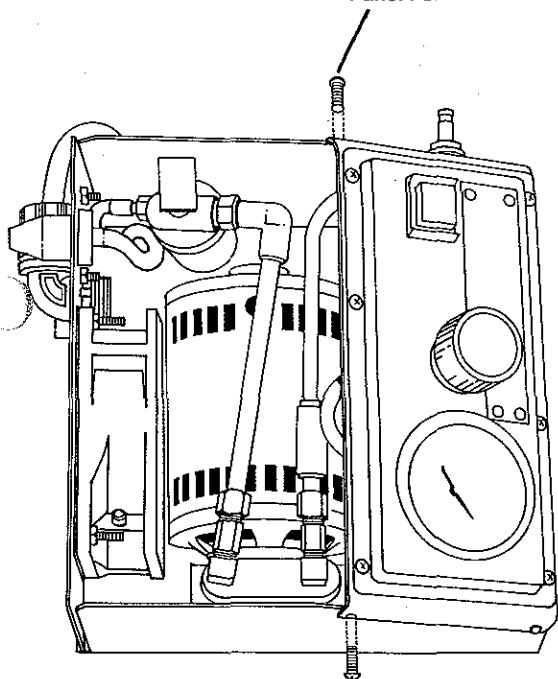

To Close:  
Push Down Here  
to Rotate Elbow  
and Avoid  
Kinking the  
Tubing

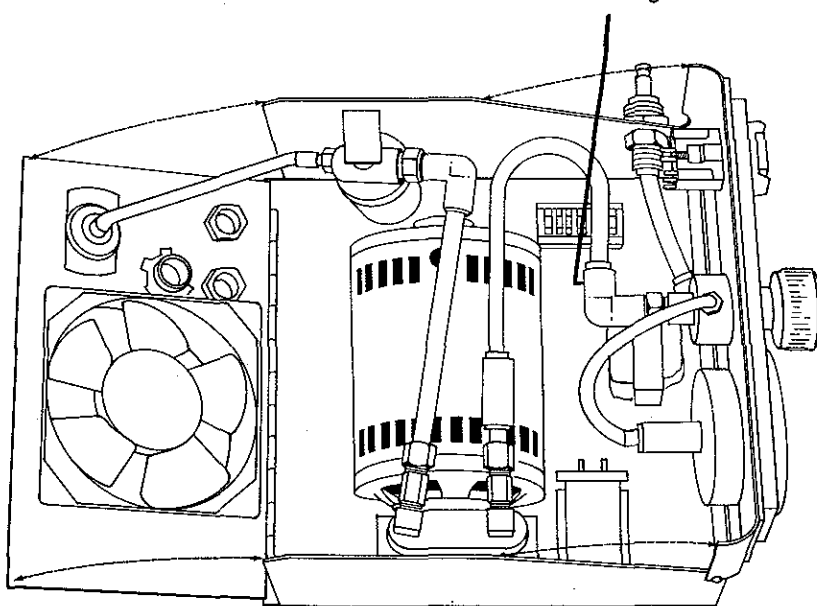

## Part Numbers and Description

2501 ASY	Safety Overflow Trap Assembly	5644	Vacuum Gauge
2507	Safety Overflow Bottle only	5688 ASY	Transformer
2535 ASY	Regulator Assembly	5656 ASY	On/Off Switch
5554	Cooling Fan	5723	Relay
5593-01	Gauge Lens	2516 ASY	Pump (with fittings)
5599	Bulb	5683	Air Inlet Filter Pad
5607-1A	Slo Bio Fuses	2509	Tinnerman Clips

# Factory-Recommended Service Parts

## Suggested Shelf Stock for Reprocessing

To be maintained by Central Supply or the using department.

### Part #5576—Disposable Bacteria Filter

This filter fits on the exhaust port of the **Instavac** and should be changed between patients.

### Part #2560ASY—Instavac Overflow Reprocessing Kit

A convenient way to return your unit to service after an overflow accident. It contains the difficult-to-clean small parts so that clean-up consists only of emptying and washing the overflow trap bottle, and installing the new float and tubing from the kit.

### On Request—Connecting Tubing

Convenient individually packaged connecting tubing in commonly used lengths. With and without and inline filter, this clean, non-sterile tubing aids in quick set-up for any procedure.

The **Instavac** will accept any of the collection canisters—disposable and reusable. The **Aeros** Collection System combines the economy of reusable glass with the safety and convenience of disposable cap, float and tubing. If the **Aeros** system is used:

- **2026—Cap Bracket for Aspirator Mount**  
and
- **2022-1—1300cc Glass Collection Jar**  
—Provided as standard items with each unit. These are reusable but a spare may be desirable.

- **2300—Disposable Cap with Built-In Float**  
An individually packaged single patient cap and float.

—OR—

- **2311ASY—Instavac Turnaround Kit**  
The 2300 cap plus float plus connecting tubing with in-line filter to facilitate between-patient turnaround.

## Suggested Shelf Stock for Preventative Maintenance and Service:

To be maintained by biomedical or maintenance department.

- **2561ASY—Preventative Maintenance Kit**  
This kit is required for the semi-annual P.M. procedure. A sample is included with each unit for the warranty period.
- **5725—Flushing Solution**  
This is required for the P.M. procedure but is ordered separately.

Following service of any kind on suction equipment, the vacuum levels and flows should be verified to be sure the unit is still within specifications and properly calibrated. The **Aeros Vac-U-Test** 5780 is a precision instrument that measures vacuum flows and vacuum levels for all portable equipment as well as wall outlets. If adequate instrumentation is not available, **Vac-U-Test**, which comes in its own carrying case, will prove to have many uses.

## Warranty

**Aeros** warrants that the Model 2500 **Instavac**® Aspirator to be free from defects in material and workmanship at the date of shipment. All claims under the warranty must be made and delivered to **Aeros** prior to the expiration of one year from the date of shipment from the factory or be barred. Units returned within one year will be repaired or replaced under the warranty regardless of reason for failure. Should failure be due to neglect or abuse, a report on reasons for failure will accompany the returned unit. Should the same unit be

returned a second time and the failure is due to neglect or abuse, a charge will be made. Transportation charges in all cases will be at the customer's expense and the customer's sole and exclusive remedy under this warranty shall in no case exceed the value of the Model 2500 **Instavac** Aspirator.

**This warranty is expressly in lieu of any other warranties, express or implied, including any warranty of merchantability or fitness for a particular purpose. Seller shall not be liable for incidental, collateral, consequential or special damages.**

# LOOK TO AEROS FOR A COMPLETE LINE OF EQUIPMENT, ACCESSORIES AND SUPPLIES TO SERVE YOUR SUCTION THERAPY NEEDS.

## A Complete Aeros Line

### EQUIPMENT AND ACCESSORIES

Satisfy all your portable suction requirements... add versatility and precision to your piped and portable equipment.

**(A) MOBLVAC 5500A**... completely universal, portable suction machine capable of performing both constant and intermittent procedures... provides many of the same operating characteristics of the Instavac Aspirator, only more.

**(B), (C) SECONDARY REGULATOR**... 5731 with Hose Barb  
5730 with Bottle...

a true vacuum regulator specifically designed for the low-vacuum levels required in neonatology and special procedure laboratories... calibrated in both 0 to 60 cm H<sub>2</sub>O and 0 to 45 mm Hg. May be used with piped or portable vacuum. When mounted on the MOBLVAC, the regulator provides two vacuum levels from a single machine.

**(D) NEEDLE VALVE 5643**... a simple vacuum-control valve that regulates bubbling in the manometer chamber of all chest drainage kits or in any other system needing finely adjusted ungauged vacuum.

**(E) THORACIC MANOMETER 4550**... a convenient, reusable underwater seal and manometer... equivalent to two bottles of the familiar three-bottle system... may be mounted at eye level on a wall slide or on the back pole of the MOBLVAC... for use with both piped or portable suction. One of the simplest and most economical chest drainage systems available... and it has the "bubble" regulator and all the safety features already built in.

**(F) CANISTER BASKET 5738**... a canister holder for any of the three lower sites on the MOBLVAC... for easy placement of any jar or canister... permits simple removal for emptying or charting.

**(G) VAC-U-TEST 5780**... a precision instrument that measures vacuum flows (from 8LPM to 150LPM) and vacuum levels (from 0 to 760 mm Hg) for all portable equipment as well as wall outlets.

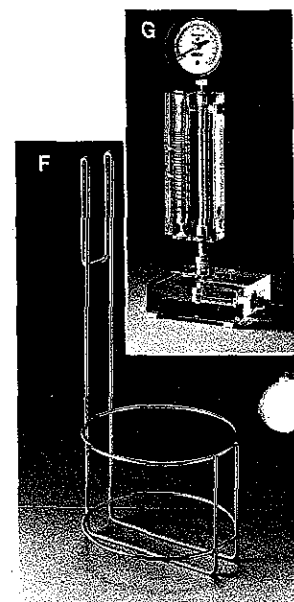
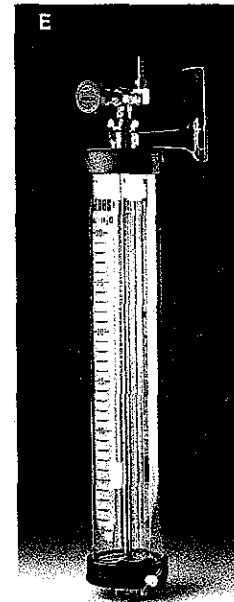
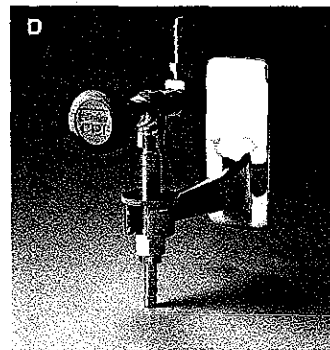
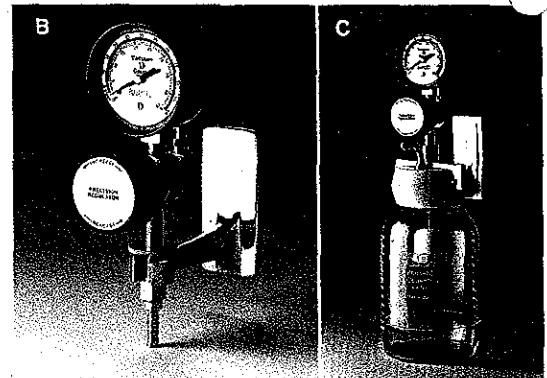
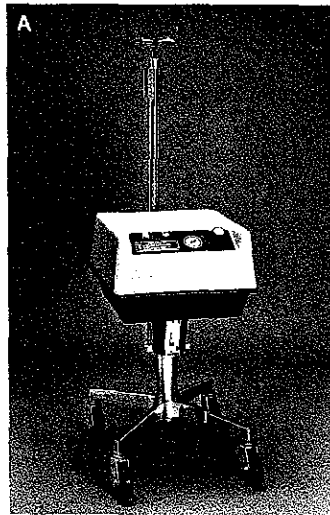

### SUPPLIES

Add safety as well as cost-effective convenience to each suction therapy procedure.

**(A) BREAST EXPRESSION KIT 5660**... a shield and bottle kit for the expression of breast milk... which provides the mother with fingertip control of the suckling cycle. A built-in relief orifice reduces tissue stress... for use with both portable and piped vacuum.

**(B) EXHAUST FILTER 5576**... disposable bacterial filter fits the exhaust port of all Aeros portable suction machines... traps aerosol rather than permitting it to be broadcast into the patient atmosphere.

**(C) AEROS COLLECTION SYSTEM**... combines the economy of a reusable glass jar with the safety and convenience of a disposable cap. Snap the positive-seal cap with built-in overflow protection on an easily cleaned glass jar for a cost-effective collection system... for piped and portable systems.

**(D) TUBING**... conveniently packaged clean tubing specifically for suction procedures in commonly used lengths... with and without inline bacterial filters.

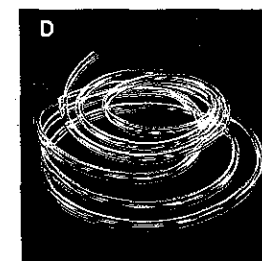
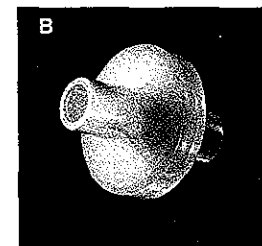
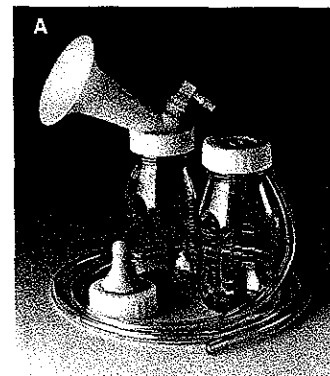

# aeros®

Aeros Instruments, Inc.  
3411 Commercial Avenue  
Northbrook, Illinois 60062  
708 584 8000 • 1 800 562 5822

PART NO. 1504-02