

Whitney Museum of American Art

1968 Annual Exhibition

Sculpture





Digitized by the Internet Archive
in 2013

<http://archive.org/details/1968annualwhit>

1968 Annual Exhibition

Contemporary American Sculpture

December 17, 1968 - February 9, 1969

Whitney Museum of American Art

945 Madison Avenue, New York



Ernest Trova Study Falling Man: 5' Walking Man With Devices

Foreword

Since 1932 the Whitney Museum has held a series of annual and biennial exhibitions surveying the field of contemporary American art. In the present exhibition, like its predecessors, the artists participate by invitation instead of submitting to a jury, and works are selected by members of the Museum's staff. By a tradition which goes back to Gertrude Vanderbilt Whitney's first activities in American art, no prizes are awarded in this exhibition.

The 1968 Annual is devoted entirely to sculpture. The exhibition is more national in scope, as were those of 1966 and 1967. This was made possible by a grant from the Ford Foundation which enabled the Museum's staff to visit art centers throughout the United States.

The exhibition is made possible by the cooperation of art galleries, private collectors and artists who have generously made loans to the exhibition and to whom we wish to make grateful acknowledgment.

Since 1960, a larger catalogue with more illustrations has been published due to the continued support of the Friends of the Whitney Museum.

Whitney Museum of American Art

Trustees

Flora Whitney Miller, *Chairman of the Board*

David M. Solinger, *President*

Flora Miller Irving, *Vice President*

Alan H. Temple, *Secretary and Treasurer*

Arthur G. Altschul

John I. H. Baur

Henry F. du Pont

Armand G. Erpf

B. H. Friedman

Lloyd Goodrich

W. Barklie Henry

Michael H. Irving

G. Macculloch Miller

Hermon More (honorary)

Roy R. Neuberger

Mrs. Laurance S. Rockefeller

Robert W. Sarnoff

Benno C. Schmidt

Cornelius Vanderbilt Whitney

Mrs. John Hay Whitney

Getrude Vanderbilt Whitney, *Founder*

Staff

John I. H. Baur, *Director*

Lloyd Goodrich, *Advisory Director*

Stephen E. Weil, *Administrator*

John Gordon, *Curator*

Margaret McKellar, *Executive Secretary*

Robert M. Doty, *Associate Curator*

Libby Seaberg, *Librarian*

Eugene N. Lewis, *Acting Head, Education Department*

Leon Levine, *Public Relations*

Margaret M. Watherston, *Conservator*

Amelia McCall Penders, *Assistant Secretary*

Althea Borden, *Personnel Supervisor*

Sally J. Kuhn, *Executive Secretary, Friends of the Whitney Museum*

Frank Russell, *Sales & Information*

Marie Appleton

John Murray, *Superintendent*

John E. Martin, *Head Preparator*



Bennett Bean Untitled

All addresses are in New York City unless otherwise noted. The number in parentheses following the artist's address indicates his dealer as listed under "Galleries." Dimensions are in inches, height preceding length or width.

Most of the works in the exhibition are for sale. Prices are available at the Information Desk.

- 1 PETER AGOSTINI b. 1913
151 Avenue B (41)
The Rocker Plaster 39½ x 40 x 42
- 2 CALVIN ALBERT b. 1918
222 Willoughby Ave., Brooklyn
Black Bull Bronze 9½ x 15 x 7
- 3 PETER ALEXANDER b. 1939
2119 Estrella, Los Angeles, Calif. (15, 20)
Untitled Polyester resin 76 x 7¾ x 7½
- 4 JOHN ANDERSON b. 1928
Box 59, Asbury, N.J. (46)
Baroque Wood 96 x 96 x 96
- 5 STEPHEN ANTONAKOS b. 1926
435 West Broadway (18)
Ruby and Pink Aluminum, neon, electric
circuitry 36 x 42 x 24
- 6 RICHARD ARTSCHWAGER b. 1924
65 East Broadway (6)
100 Locations Paint, hair, wood, plastic
Indeterminate dimensions
- 7 JERRY BALLAINE b. 1934
2129½ Russell, Berkeley, Calif.
H. and Hardart Number 14 Plastic, lacquer
50 x 60 x 12
- 8 ROBERT BART b. 1923
113 Greene St. (38)
Mandala Number 3 Aluminum, stainless steel
66 x 66 x 66
- 9 LEONARD BASKIN b. 1922
Fort Hill, Northampton, Mass. (3)
Oedipus at Colonus Bronze 74 x 29 x 29
- 10 MARY BAUERMEISTER b. 1934
119 Ridgewood St., Madison, Conn. (2)
All Things Involved in All Other Things Wood,
glass, paint 90 x 60 x 45

- 11 BENNETT BEAN b. 1941
1831 South Ave., Staten Island
Untitled Plexiglas 72 x 36 x 4½
- 12 JOHN BENNETT b. 1935
300 Canal St. (18)
Lady Slipper Fiberglas, lacquer, wood
48 x 32 x 32
- 13 FLETCHER BENTON b. 1931
2100 Pine St., San Francisco, Calif. (2)
Synchronetic L 443 Aluminum, plexiglas,
electric circuitry 22 x 21 x 21
- 14 TONY BERLANT b. 1941
2802 2nd St., Santa Monica, Calif. (47)
The Cracked White House Steel, plywood
83 x 72½ x 71
- 15 BEN BERNS b. 1936
505 West 23 St.
Number 13 Neon, fiberglas 45 x 60 x 27¾
- 16 MICHAEL BIGGER b. 1937
207 Williams St., Providence, R.I.
Love Me #6 Steel 110 x 12 x 48
Lent by Joseph S. Sinclair, Providence, R.I.
- 17 RONALD BLADEN b. 1918
182 Fifth Ave. (18)
Construction Lumber Wood, paint
186 x 288 x 168
- 18 VARUJAN BOGHOSIAN b. 1926
Dartmouth College, Hanover, N.H. (9)
Coronation Wood, iron, clay, brass
74 x 47½ x 13
- 19 LEE BONTECOU b. 1931
147 Wooster St. (6)
Untitled Acetate 96 x 45 x 40
- 20 LOUISE BOURGEOIS b. 1911
347 West 20 St.
Sleep II Marble 23½ x 24 x 31
- 21 ALEXANDER CALDER b. 1898
Roxbury, Conn. (39)
Four at Forty-Five (degrees!) Sheet metal, steel
rods 38 x 256 x 256
- 22 KENNETH CAMPBELL b. 1913
79 Mercer St. (14)
Popeye Marble 84 x 18 x 36
- 23 JOHN CHAMBERLAIN b. 1927
405 East 13 St. (6)
Brophill Lowdown Galvanized iron
59¾ x 56 x 50
- 24 CHRYSSEA b. 1933
27 East 83 St.
Cents Minus Steel, enamel, plexiglas, ink
78½ x 28 x 42
- 25 MIKE COOPER b. 1943
c/o Esther Robles Gallery, 665 N. La Cienega,
Los Angeles, Calif.
Time Capsule Chromed steel 60 x 48 x 48
- 26 TONY DELAP b. 1927
225 Jasmine St., Corona del Mar, Calif. (15, 31)
Sutro Anodized aluminum, plexiglas
48 x 96 x 48
- 27 WALTER DE MARIA b. 1935
27 Howard St. (13)
Garbo Column Aluminum 72 x 4½ x 4
Lent by Mr. and Mrs. Robert A. Rowan,
Pasadena, Calif.
- 28 DEBORAH DE MOULPIED b. 1933
248 Pine Orchard Rd., Branford, Conn. (7)
Palamos Plexiglas 32 x 47½ x 35¼
- 29 JOSE DE RIVERA b. 1904
40-40 24th St., Long Island City, N.Y. (3)
Construction Number 106 Stainless steel
28 x 24 x 17

- 30 MARK DI SUVERO b. 1933
195 Front St. (1, 8)
To Martin Luther King Steel 44 x 72 x 41½
Lent by the Joseph H. Hirshhorn Collection
- 31 TOM DOYLE b. 1928
135 Bowery (13)
Ringgold Fiberglas, paint 38 x 31 x 109
- 32 ROBERT ENGMAN b. 1927
Haverford, Pa. (7)
Aspects of a Tone Poem Bronze, paint
14 x 12½ x 5½
- 33 PETER ERSKINE b. 1941
East Chatham, N.Y.
The Undiscovered Self Styrofoam, dynel, epoxy
18 x 79 x 65
- 34 HERBERT FERBER b. 1906
827 Broadway (16)
Circle and Calligraph III Copper 71 x 54 x 24
- 35 FRANK GALLO b. 1933
804 West Nevada, Urbana, Ill. (23)
Man with Necktie Epoxy 23¾ x 11½ x 11
- 36 WILLIAM GEIS, III b. 1940
P.O. Box 85, Woodacre, Calif. (40)
Perusal's Oar Wood, fiberglas, plaster, paint
96 x 60 x 72
- 37 CRISTOS GIANAKOS b. 1934
138 Prince St.
Sculpture Number 10 Polyester resin
24 x 30 x 30
- 38 JOHN GOODYEAR b. 1930
R.D. 1, Lebanon, N.J.
Hot and Cold Bars Aluminum, plastic, electric
circuitry 5¾ x 5¾ x 72
- 39 ROBERT GRAHAM b. 1938
1233 S. Ogden Dr., Los Angeles, Calif. (30)
Untitled Mixed media 12 x 22 x 22
- 40 NANCY GROSSMAN b. 1940
105 Eldridge St. (9)
Head (2 Stars) Leather, wood, epoxy paint
16 x 7 x 9
Collection of the Whitney Museum of American
Art, Gift of the Howard and Jean Lipman
Foundation, Inc.
- 41 ROBERT GROSVENOR b. 1937
302 Elizabeth St. (18)
Untitled Plywood, steel, fiberglas, paint
108 x 384 x 18
- 42 ROY GUSSOW b. 1918
40-40 24th St., Long Island City, N.Y. (3)
Three Columns, 5-15-68 Stainless steel sheet
36½ x 27 x 26
- 43 PETER GUTKIN b. 1944
607 Hemlock, San Francisco, Calif. (24)
Untitled Alder wood, plastics 47 x 36 x 36
- 44 MICHAEL HALL b. 1941
Rt. 7, Grimes Mill Rd., Lexington, Ky.
Mastodon VI Aluminum, bronze 37 x 88 x 24
- 45 DUAYNE HATCHETT b. 1935
c/o Royal Marks Gallery, 19 East 71 St.
Go Aluminum, acrylic plastic 92 x 111 x 84
- 46 ALEX HAY b. 1930
27 Howard St. (30)
Paper Bag Paper, epoxy, fiberglas, paint
60 x 29 x 17¾
- 47 MICHAEL HEIZER b. 1944
79 Mercer St.
City Depression Plated metal, displaced paving
stones 4 x 144 x 48
- 48 EVA HESSE b. 1936
134 Bowery (18)
Sans Fiberglas 5 units, each 38 x 85 x 7

- 49 WILL HORWITT b. 1934
131 East 15 St. (41)
Landscape in a Minimal World Bronze
16½ x 25 x 13
- 50 ROBERT HOWARD b. 1922
Ackland Art Center, Chapel Hill, N.C. (33)
I-68 Steel, paint 64 x 100 x 48
- 51 ROBERT HUDSON b. 1938
White Gate Ranch, Bolinas, Calif. (19)
Black Lift Steel 84 x 72 x 72
- 52 RICHARD HUNT b. 1935
1503 N. Cleveland Ave., Chicago, Ill. (12)
Hybrid Form Steel 17½ x 29 x 20
- 53 JAMES HUNTINGTON b. 1941
29 Park Row (36)
Idria Nacreous metallic acrylic, canvas, wood
66 x 66 x 12
- 54 DANIEL LARUE JOHNSON b. 1938
109 Spring St.
Eve Wood, paint 36 x 38 x 12
- 55 DONALD JUDD b. 1928
53 East 19 St. (6)
Untitled Anodized aluminum 48 x 61 x 108
- 56 CRAIG KAUFFMAN b. 1932
c/o Pace Gallery, 32 East 57 St.
Untitled Plexiglas 24 x 60 x 10
- 57 ELLSWORTH KELLY b. 1923
1 West 67 St. (26)
Untitled (white) Aluminum, paint
100½ x 146½ x 38⅜
Lent by William Rubin, N. Y.
- 58 WILLIAM KING b. 1925
17 East 96 St. (11)
The Interview Aluminum 52 x 14 x 10
- 59 ROBERT KINMONT b. 1937
500 San Francisco Blvd., San Anselmo, Calif.
36 *Flavors* Wax, neon, wood 86 x 17 x 4
- 60 LYMAN KIPP b. 1929
North Salem, N.Y.
Hudson Bay Steel, paint 108 x 96 x 96
- 61 GABRIEL KOHN b. 1910
10806 Ventura Blvd., N. Hollywood, Calif. (47)
Ventura #10 Pine, beech, redwood 25 x 22 x 16
- 62 JOSEPH KONZAL b. 1905
254 Warren St., Brooklyn (43)
Sparta Bronze 23½ x 9½ x 7½
- 63 ROCKNE KREBS b. 1938
1960 Baltimore St., N.W., Washington, D.C. (5)
Untitled Scotchlite, aluminum 154 x 154 x 120
- 64 GARY KUEHN b. 1939
1551 Westbrook Rd., Somerville, N.J. (1)
Untitled Wood, fiberglass, enamel 30 x 48 x 21½
- 65 GERALD LAING b. 1936
141 Greene St. (17)
Gold Standard Steel, paint 4½ x 48½ x 45½
- 66 LEROY LAMIS b. 1925
3101 Oak St., Terre Haute, Ind. (45)
Construction 143 Plexiglas 37 x 13 x 13
- 67 STANLEY LANDSMAN b. 1930
35 West 26 St. (6)
Flora Wood, glass, electric circuitry
72 x 24 x 24
- 68 MICHAEL LEKAKIS b. 1907
57 West 28 St.
Apotheosis Oak 102 x 60 x 48
- 69 JOSEPH LEVI b. 1938
171 West 71 St. (44)
Sarigan Metal, electric circuitry, paint
103½ x 58 x 18

- 70 LES LEVINE b. 1936
119 Bowery (18)
Black Star Plexiglas 66 x 94 x 102
- 71 ALEXANDER LIBERMAN b. 1912
173 East 70 St. (16)
Arc Steel, paint 111½ x 147 x 108
- 72 ROY LICHTENSTEIN b. 1923
190 Bowery (6)
Modern Sculpture with Velvet Rope Brass, velvet rope 2 parts, 83¼ x 26 x 15 and 59 x 26 x 15
- 73 SEYMOUR LIPTON b. 1903
302 West 98 St. (34)
Catacombs Nickel silver on monel metal
83 x 67 x 34
- 74 JIM LOVE b. 1927
908 Truxillo, Houston, Texas (28)
Portable Bunker for Family Quarrels Steel, sand bags 9½ x 10½ x 5
- 75 BIX LYE b. 1937
801 Greenwich St.
Snack II Nova ply, epoxy, lacquer, lucite
10¼ x 7¼ x 6¼
- 76 SHELDON MACHLIN b. 1918
39 Columbia Pl., Brooklyn (48)
Silver Trimble Steel, paint 24 x 6½ x 6½
- 77 ROBERT MALLARY b. 1917
85 N. Whitney St., Amherst, Mass. (46)
Quad III TRAN2 Computer sculpture in laminated veneer 68½ x 11½ x 11
- 78 JOHN McCracken b. 1934
20 East 17 St. (15)
Untitled Plywood, paint 120 x 32 x 80
- 79 ED McGOWIN b. 1938
1215 Fort Myer Dr., Arlington, Va. (25)
Squinches Plexiglas 144 x 72 x 54
- 80 WALTER McNAMARA b. 1939
720 Milton Circle, Reno, Nev.
Soft Ware with Non-Tongue Plaster, copper
96 x 30 x 12
- 81 CLEMENT MEADMORE b. 1929
317 West 99 St. (5)
U Turn Painted Cor-ten steel 87 x 168 x 132
- 82 JAMES MELCHERT b. 1930
6077 Oceanview Dr., Oakland, Calif. (24, 36)
Photo Negative with Ashtray on Blue Table
Ceramic 4 x 15 x 15
- 83 ROBERT MORRIS b. 1931
c/o Leo Castelli Gallery, 4 East 77 St.
Untitled Aluminum 36 x 144 x 144
- 84 ROBERT MURRAY b. 1936
138 East 22 St. (38)
Chinook Aluminum, paint 144 x 192 x 48
- 85 LOUISE NEVELSON b. 1900
29 Spring St. (37)
Canada Series III Plexiglas 42½ x 27 x 7½
Lent by Mr. and Mrs. Lester Avnet,
Great Neck, N. Y.
- 86 BARNETT NEWMAN b. 1905
685 West End Ave. (30)
Here III Stainless steel, Cor-ten steel
125 x 23½ x 18½
- 87 MINORU NIIZUMA b. 1930
87 Christopher St. (50)
Windy Wind Marble 75 x 10 x 10
Lent by Roy D. Beemer, Beverly Hills, Calif.
- 88 CLAES OLDENBURG b. 1929
404 East 14 St. (26)
Giant Soft Ketchup Bottle with Ketchup Canvas,
foam rubber 100 x 200 x 24

- 89 DENNIS OPPENHEIM b. 1938
294 State St., Brooklyn (21)
Decomposition—Whitney Museum Mixed media
13 x 120 x 96
- 90 ALFONSO OSSORIO b. 1916
The Creeks, Easthampton, N.Y. (9)
Congregation #3 Mixed media 106 x 36 x 17
Lent by Morris J. Pinto, Paris
- 91 HAROLD PARIS b. 1925
1401 Middle Harbor Rd., Oakland, Calif. (24)
*Conversation on a Black Afternoon: April 4, 1968,
6:01 P.M.* Wood, plastic 51 x 72 x 53
- 92 KENNETH PRICE b. 1935
2360 S. Robertson, Los Angeles, Calif.
R. G. Violet Ceramic 5 x 3½ x 9
Lent by Jackie and Ulf Greber, Beverly Hills, Calif.
- 93 LEO RABKIN b. 1919
218 West 20 St.
Calligraphy-Box Plexiglas, paper, electric
circuitry 12½ x 10½ x 10½
- 94 CARLOS RAMOS b. 1940
c/o Barden, 69 Horatio St.
Untitled Fiberglas 59 x 37 x 15
- 95 JAMES REINEKING b. 1937
3178 17th St., San Francisco, Calif. (40)
Untitled Sitting Object / 2nd Edition Paint, wood,
plexiglas, electric circuitry 12 x 24 x 24
- 96 SAM RICHARDSON b. 1934
c/o Esther Robles Gallery, 665 N. La Cienega,
Los Angeles, Calif.
*The Fog Bank Hangs Over Six Miles of that Guy's
River* Fiberglas, polyfoam, plastic, lacquer
40 x 71¼ x 6¾
- 97 ROBERT RICHENBURG b. 1917
359 West Broadway
Clear Sailing Polyethylene plastic 72 x 60 x 24
- 98 GEORGE RICKEY b. 1907
R.D. 2, East Chatham, N. Y. (45)
Two Lines Oblique Stainless steel
120 x indeterminate w. x 4"
- 99 LARRY RIVERS b. 1923
404 East 14 St. (34)
Cropped Blue Bed Wood, canvas
47½ x 48 x 40¾
- 100 HENRY ROLLINS b. 1937
249 Redwood Rd., San Anselmo, Calif.
The Sun Brass, bronze 14 x 14 x 14
- 101 JAMES ROSATI b. 1912
252 West 14 St. (34)
Horizon II Bronze 108 x 84 x 72
- 102 BERNARD ROSENTHAL b. 1914
358 East 57 St. (29)
Odyssey Aluminum, paint 78 x 98 x 90
- 103 CHARLES ROSS b. 1937
80 Wooster St. (13)
Prism Pair—Left and Right Exchange Plexiglas,
mineral oil two parts, each 36 x 60 x 28
- 104 THEODORE ROSZAK b. 1907
1 St. Lukes Pl. (35)
Vector—Study for Architectural Wall
Mixed Media 60 x 96
- 105 LUCAS SAMARAS b. 1936
52 West 71 St. (37)
Transformation: Flowers Mixed media
53⅜ x 35 x 31
- 106 FRED SANDBACK b. 1943
401 8th Ave., Brooklyn (13)
Trapezoid Orange elastic cord 108 x 108 x 24
- 107 ALAN SARET b. 1944
130 Greene St. (4)
True Jungle: Canopy Forest Wire, paint
108 x 206 x 4½

- 108 JULIUS SCHMIDT b. 1923
Cranbrook Academy of Art, Bloomfield Hills,
Mich. (34)
Untitled Bronze 29½ x 25 x 21
- 109 ROY SCHNACKENBERG b. 1934
2600 N. Racine, Chicago, Ill.
Woman in Tub Hydrastone 9 x 8 x 17
Lent by Mr. and Mrs. Richard L. Selle, Chicago, Ill.
- 110 GEORGE SEGAL b. 1924
RFD 4, Box 323, North Brunswick, N. J. (26)
Laundromat Plaster, metal, plastic 47 x 97 x 43
- 111 JASON SELEY b. 1919
209 Hudson St., Ithaca, N. Y. (30)
Hanover II Chromium plated steel 96 x 48 x 30
- 112 WILLIAM SELLERS b. 1929
2734 Rush-Mendon Rd., Honeoye Falls, N. Y. (41)
Twist Stainless steel 43½ x 102 x 72
- 113 RICHARD SERRA b. 1939
319 Greenwich St. (1)
Slow Roll for Philip Glass Lead 6¾ x 72 x 7½
- 114 ROBERT SMITHSON b. 1938
799 Greenwich St. (13)
Palisades Aluminum, enamel, stone
56 x 26 x 36
- 115 KENNETH SNELSON b. 1927
36 West 26 St. (13)
Lorraine Steel, stainless steel cable, paint
120 x 120 x 180
- 116 SYLVIA STONE b. 1928
238 Park Avenue So. (10)
Monolith Plexiglas, acrylic 64 x 132 x ½
- 117 EDVINS STRAUTMANIS b. 1933
4618 N. Dover St., Chicago, Ill. (32)
Supercraft Wood, paint 57½ x 126 x 108
- 118 GEORGE SUGARMAN b. 1912
127 Greene St. (18)
Square Spiral Steel, paint 111 x 126 x 114
- 119 WAYNE TAYLOR b. 1931
189 Bowery
Blue Flake III Vinyl 103 x 63 x 16
- 120 JULIUS TOBIAS b. 1915
9 Great Jones St.
Interior Space #3 Masonite, formica
102 x 86½ x 114
- 121 MICHAEL TODD b. 1935
494 Broadway (27)
Untitled Painted Cor-ten steel 65 x 84 x 60
- 122 ERNEST TROVA b. 1927
c/o Pace Gallery, 32 East 57 St.
Study Falling Man: 5' Walking Man with Devices
Bronze 60 x 24 x 18
Lent by the McCory Corporation, N. Y.
- 123 ANNE TRUITT b. 1921
3520 Tilden St. N.W., Washington, D. C. (16)
Whale's Eye Wood, paint 60 x 18 x 18
- 124 WILLIAM TUNBERG b. 1936
903 Pacific Ave., Venice, Calif.
Neoclassical Drawing Trap Wood, epoxy, chrome
53½ x 21 x 22
- 125 DEWAIN VALENTINE b. 1936
69 Market St., Venice, Calif.
Slab Polyester 96 x 18 x 36
- 126 RICHARD VAN BUREN b. 1937
510 Broome St. (4)
Untitled, 1968 Fiberglas, charcoal
96 x 19 x 7
- 127 FRANK LINCOLN VINER b. 1939
163 Bowery
Peat Moss Plot Mixed media 54 x 54 x 12

- 128 RUTH VOLLMER
25 Central Park West (38)
In Relation Three to Four Aluminum 20 x 20 x 20
- 129 DAVID VON SCHLEGELL b. 1920
173 Christopher St. (1, 49)
Untitled Stainless steel 84 x 192 x 248
- 130 DAVID WEINRIB b. 1924
78 Greene St. (33)
Son Polyester resin 29½ x 43½ x 21½
- 131 TOM WESSELMANN b. 1931
54 Bond St. (26)
Seascape Number 5 Synthetic polymer paint,
plexiglas 65 x 44½ x 3
Collection of the Whitney Museum of American
Art. Gift of the Howard and Jean Lipman
Foundation, Inc.
- 132 H. C. WESTERMANN b. 1922
Brookfield Center, Conn. (19)
Lily Bolero Wood, glass, paint 18½ x 9¼ x 8
- 133 JOHN WILLENBECHER b. 1936
15 West 68 St. (17)
Spheremusic No. 5 Wood, glass, paint
38¼ x 38¼ x 3½
- 134 FRANKLIN WILLIAMS b. 1940
4120 Montgomery, Oakland, Calif.
Untitled Mixed media 8 x 10 x 22
- 135 CHRISTOPHER WILMARTH b. 1943
5 Lispenard St. (23)
New Plywood, glass 96 x 24 x 24
- 136 JAMES WINES b. 1932
60 Greene St. (34)
Disc and Square Steel, cement 72 x 72 x 6
- 137 GARY WOJCIK b. 1945
545 S. Limestone, Lexington, Ky. (22)
Snaker Ray Welded steel, automotive lacquer
24 x 96 x 42

Galleries

- 1 Richard Bellamy and Noah Goldowsky Gallery
- 2 Galeria Bonino
- 3 Grace Borgenicht Gallery
- 4 Bykert Gallery
- 5 Byron Gallery
- 6 Leo Castelli Gallery
- 7 Galerie Chalette
- 8 Paula Cooper
- 9 Cordier & Ekstrom
- 10 Tibor de Nagy Gallery
- 11 Terry Dintenfass, Inc.
- 12 Dorsky Gallery
- 13 Dwan Gallery
- 14 Egan Gallery
- 15 Robert Elkon Gallery
- 16 André Emmerich Gallery
- 17 Richard Feigen Gallery
- 18 Fischbach Gallery
- 19 Allan Frumkin Gallery
- 20 Gallery 669, Los Angeles
- 21 John Gibson
- 22 Gilman Galleries, Chicago
- 23 Graham Gallery
- 24 Hansen Gallery, San Francisco
- 25 Henri Gallery, Washington, D. C.
- 26 Sidney Janis Gallery
- 27 Gertrude Kastle Gallery, Detroit
- 28 Atelier Chapman Kelley, Dallas
- 29 M. Knoedler & Co., Inc.
- 30 Kornblee Gallery
- 31 Felix Landau, Los Angeles
- 32 Main Street Galleries, Chicago
- 33 Royal Marks Gallery

- 34 Marlborough-Gerson Gallery
- 35 Pierre Matisse Gallery
- 36 Obelisk Gallery, Boston
- 37 Pace Gallery
- 38 Betty Parsons Gallery
- 39 Perls Galleries
- 40 Quay Gallery, San Francisco
- 41 Stephen Radich Gallery
- 42 Esther Robles Gallery, Los Angeles
- 43 Bertha Schaefer Gallery
- 44 Stable Gallery
- 45 Staempfli Gallery
- 46 Allan Stone Gallery
- 47 David Stuart Galleries, Los Angeles
- 48 Waddell Gallery
- 49 Ward-Nasse Gallery, Boston
- 50 Howard Wise Gallery

Collections

- Mr. and Mrs. Lester Avnet, Great Neck, New York
Roy D. Beemer, Beverly Hills, California
Jackie and Ulf Greber, Beverly Hills, California
The Joseph H. Hirshhorn Collection, New York
McCrory Corporation, New York
Morris J. Pinto, Paris
Mr. and Mrs. Robert A. Rowan, Pasadena, California
William Rubin, New York
Mr. and Mrs. Richard L. Selle, Chicago, Illinois
Joseph S. Sinclair, Providence, Rhode Island
Whitney Museum of American Art, New York



Peter Agostini The Rocker

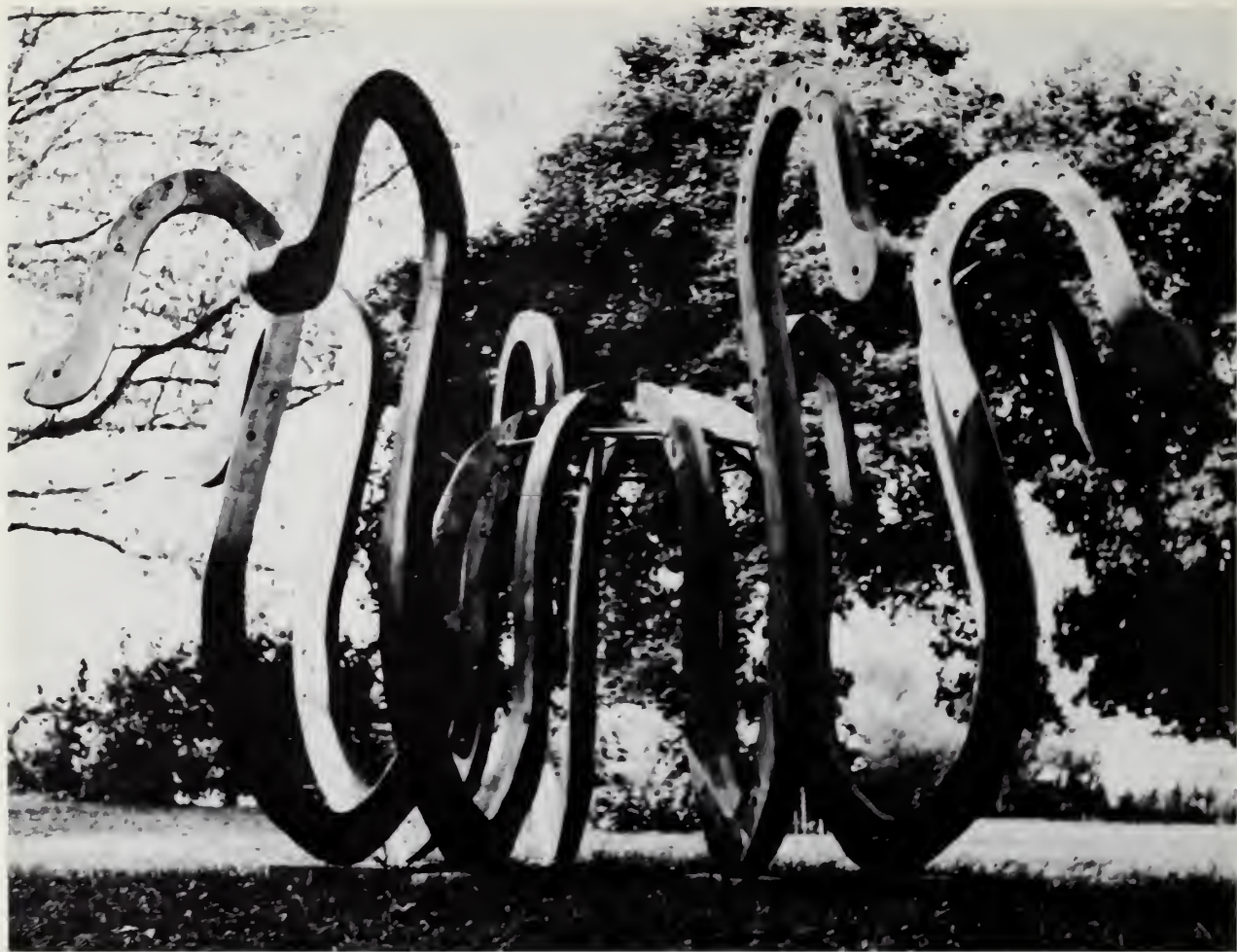

John Anderson Baroque

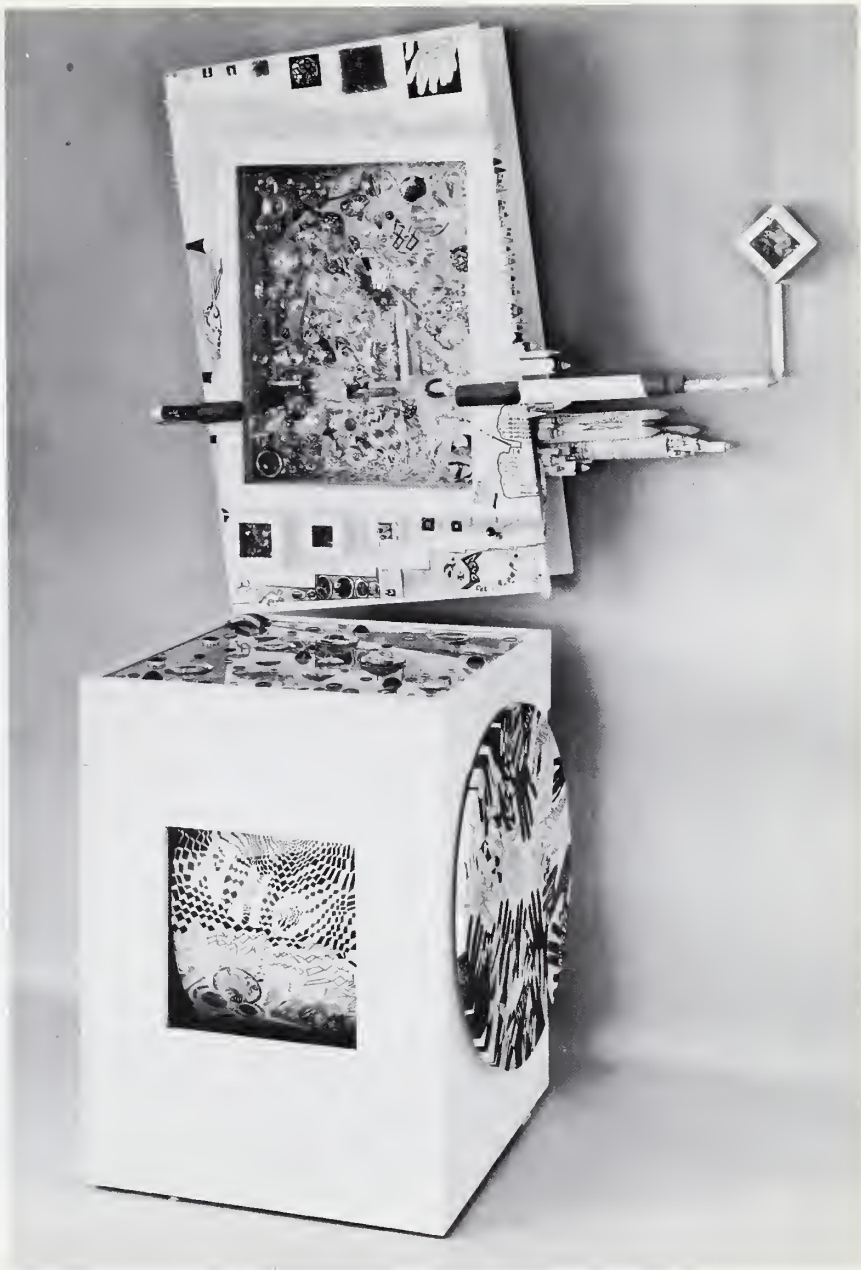

Mary Bauermeister All Things Involved in All Other Things

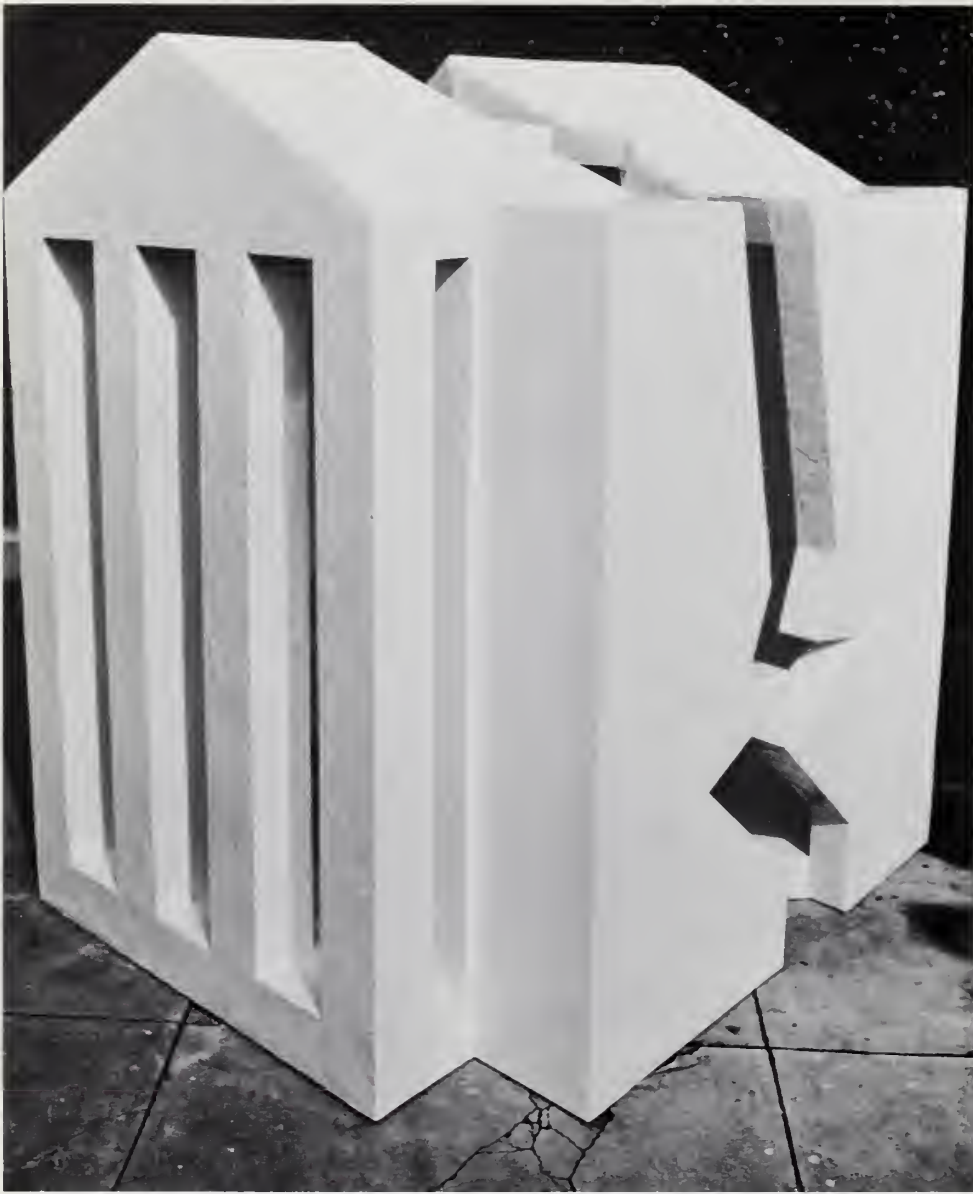

Tony Berlant The Cracked White House

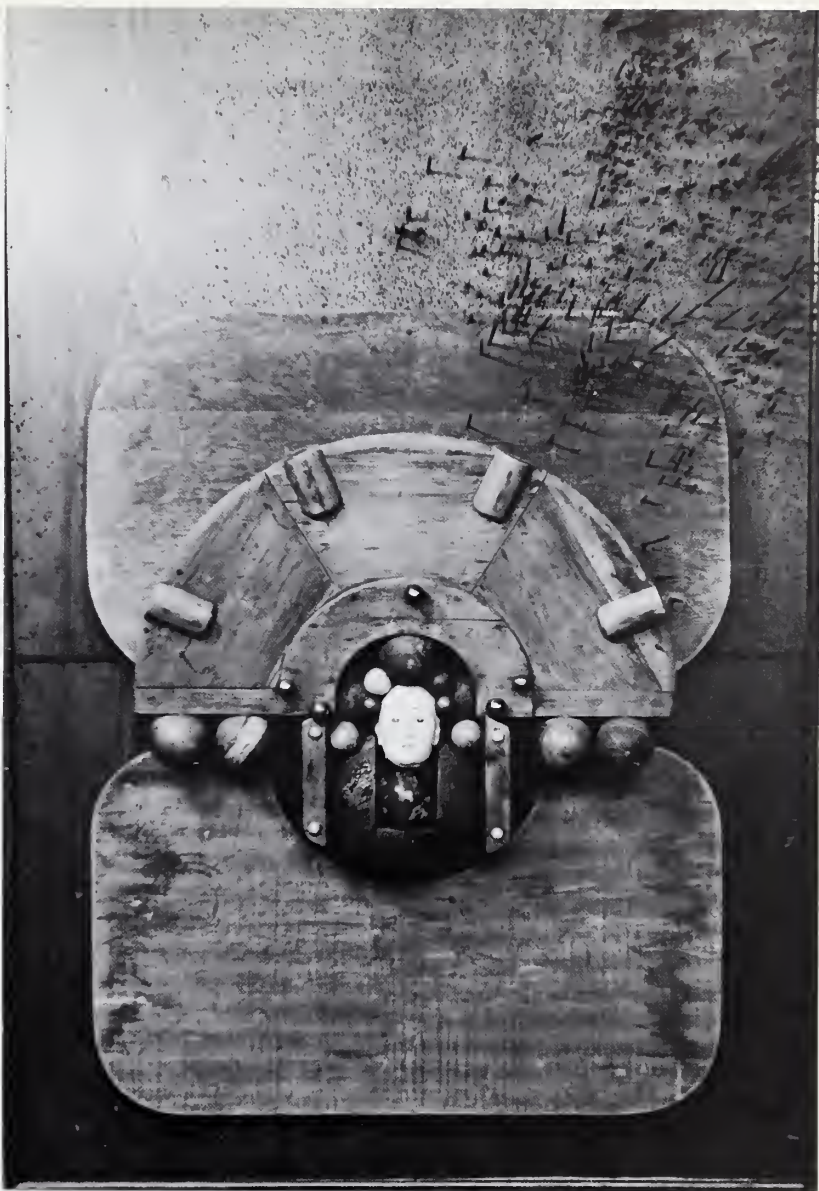

Varujan Boghosian Coronation



Louise Bourgeois Sleep II



Kenneth Campbell Popeye



Richard Artschwager 100 Locations



Peter Erskine The Undiscovered Self



Tom Doyle Ringgold



Herbert Ferber Circle and Calligraph III

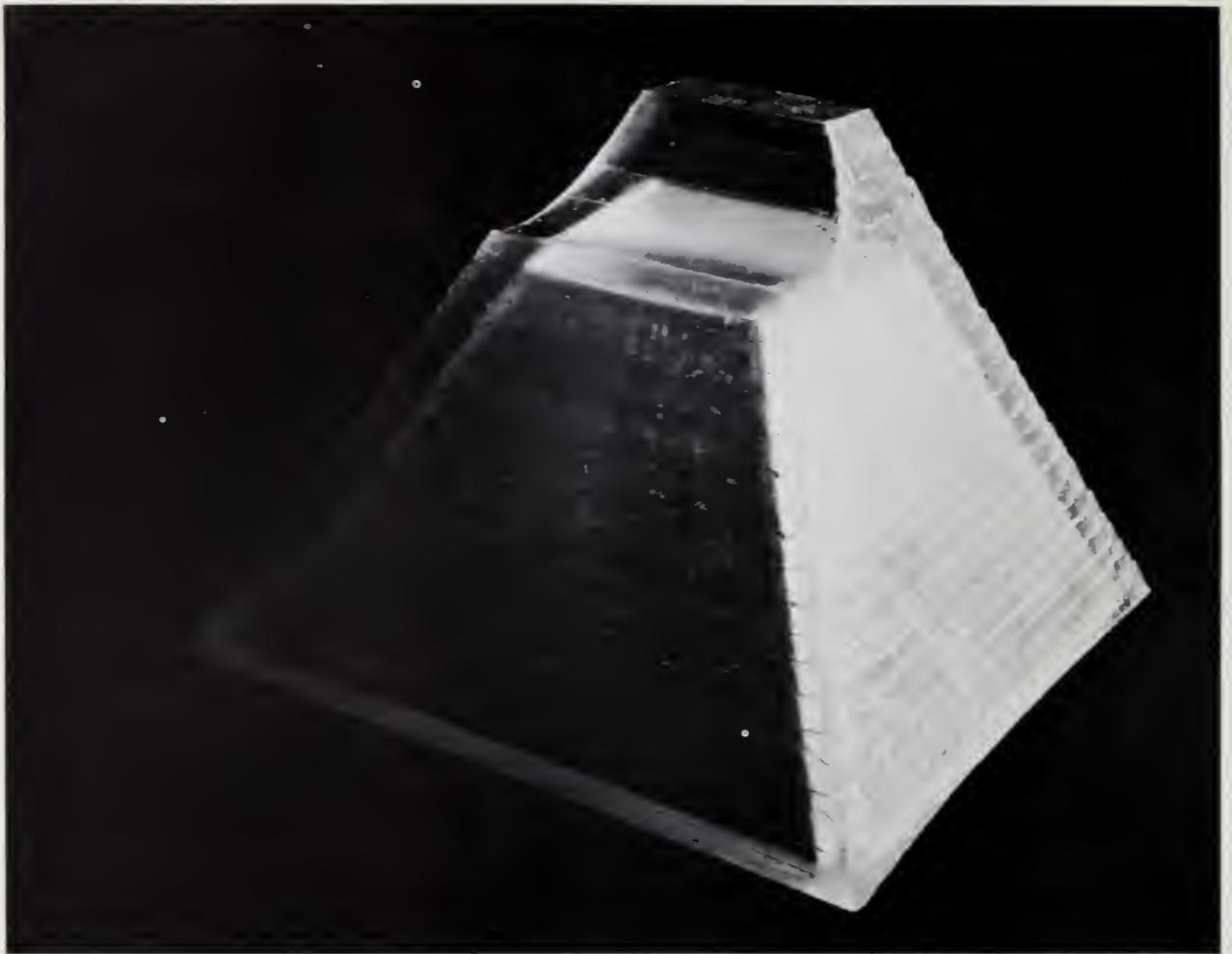

Cristos Gianakos Sculpture No. 10



Nancy Grossman Head (2 stars)

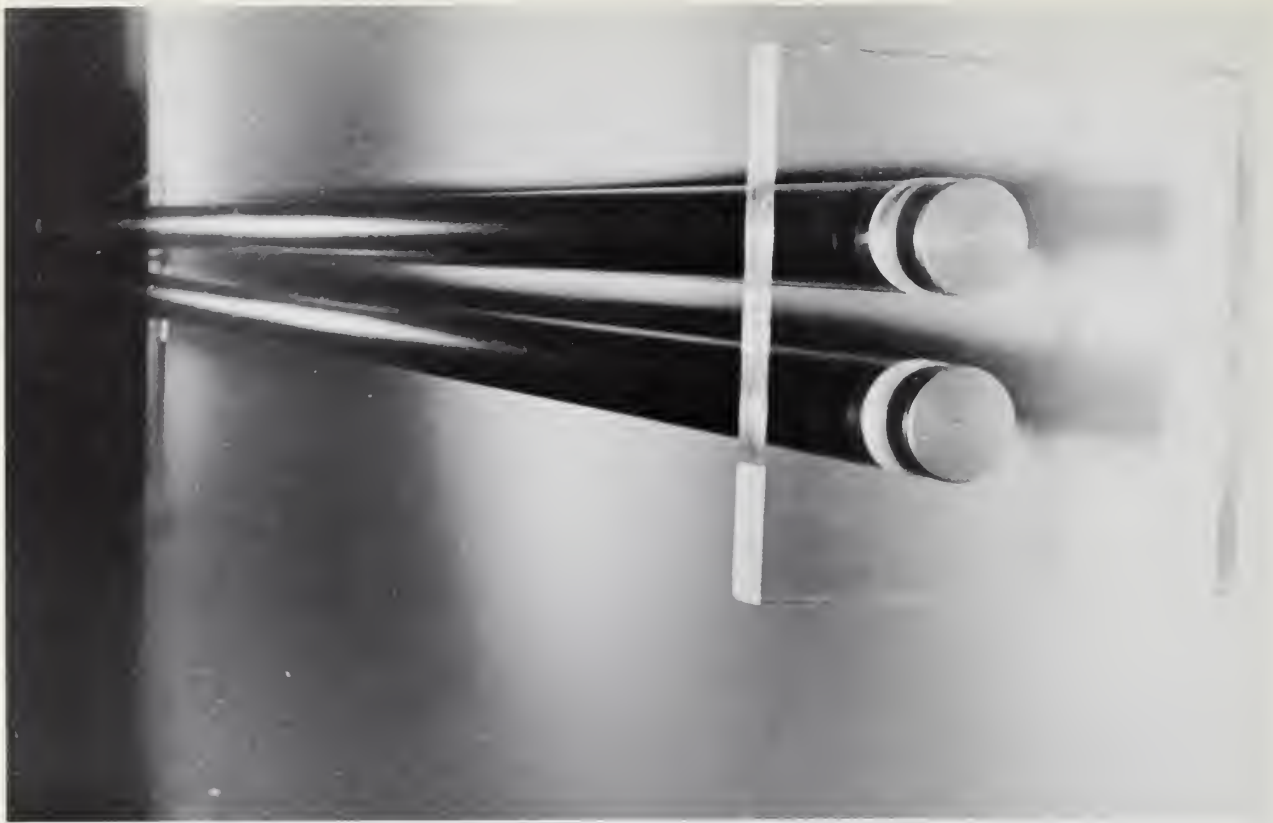

John Goodyear Hot and Cold Bars



Roy Gussow Three Columns 5-15-68

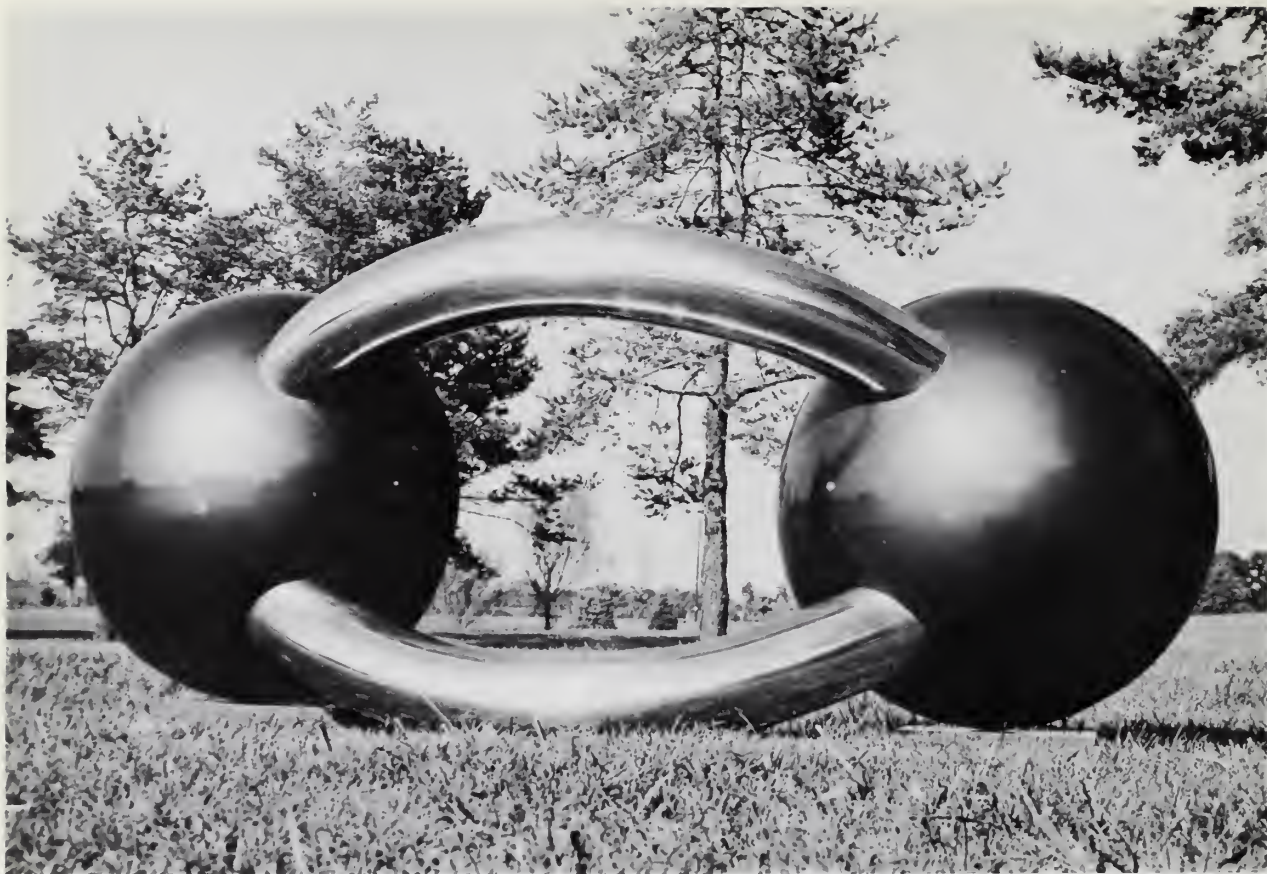

Michael Hall Mastodon VI



Duayne Hatchett Go



Alex Hay Paper Bag



Robert Howard I-68



Richard Hunt Hybrid Form



James Huntington Idria



Robert Graham Untitled



Craig Kauffman Untitled



Rockne Krebs Untitled

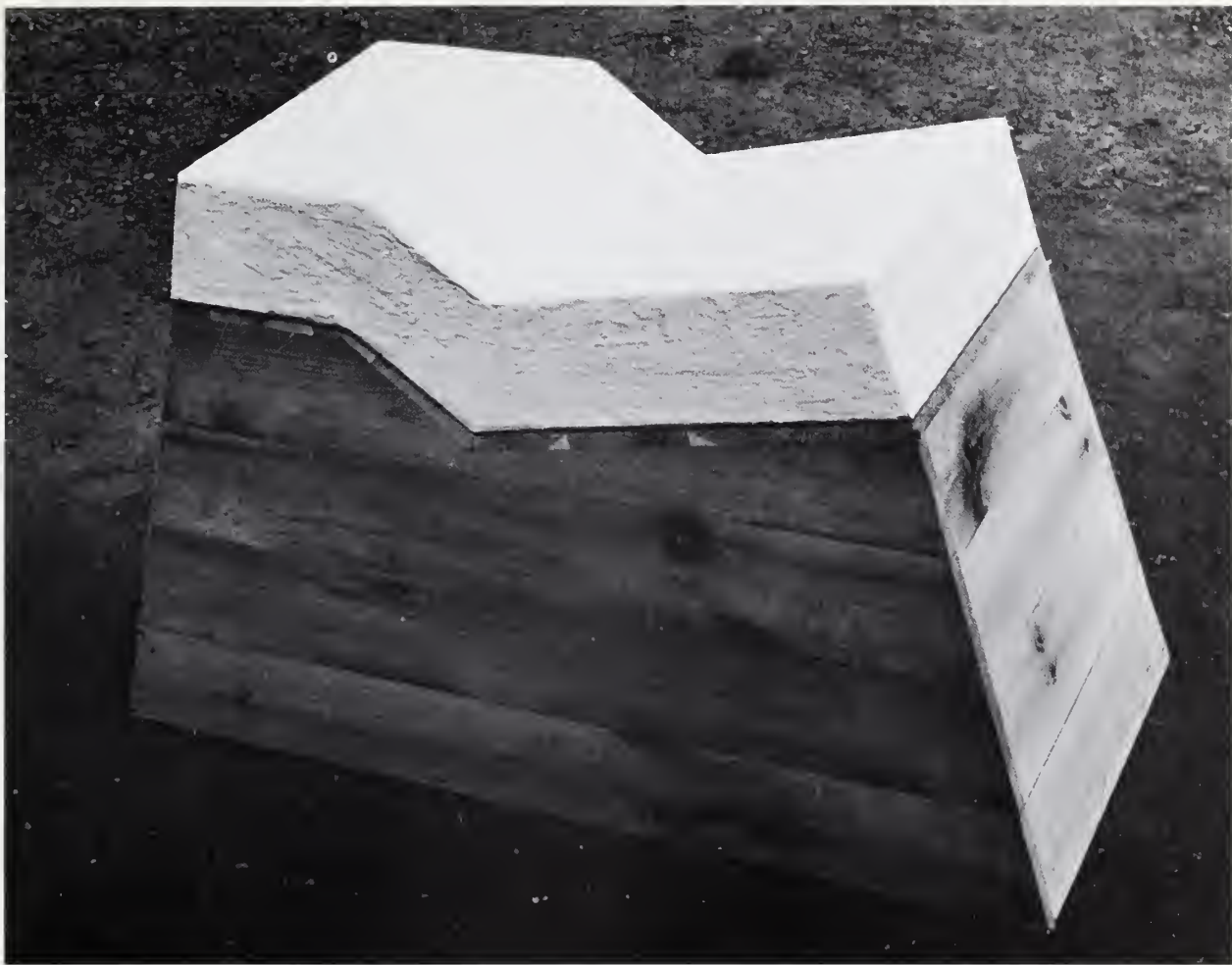

Gary Kuehn Untitled



Michael Lekakis Apotheosis



Alexander Liberman Arc



Roy Lichtenstein Modern Sculpture with Velvet Rope



Seymour Lipton Catacombs



Jim Love Portable Bunker for Family Quarrels

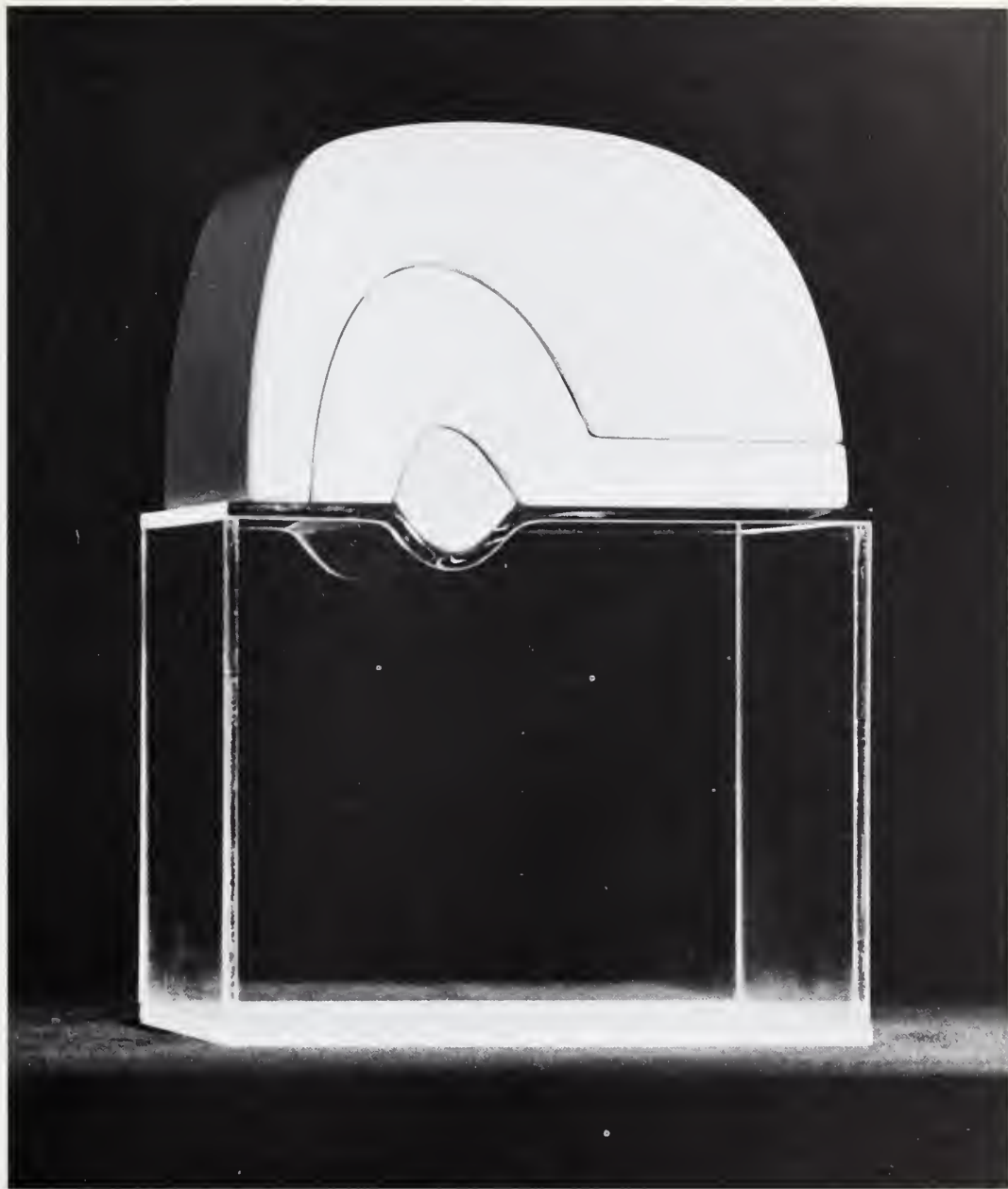

Bix Lye Snack II

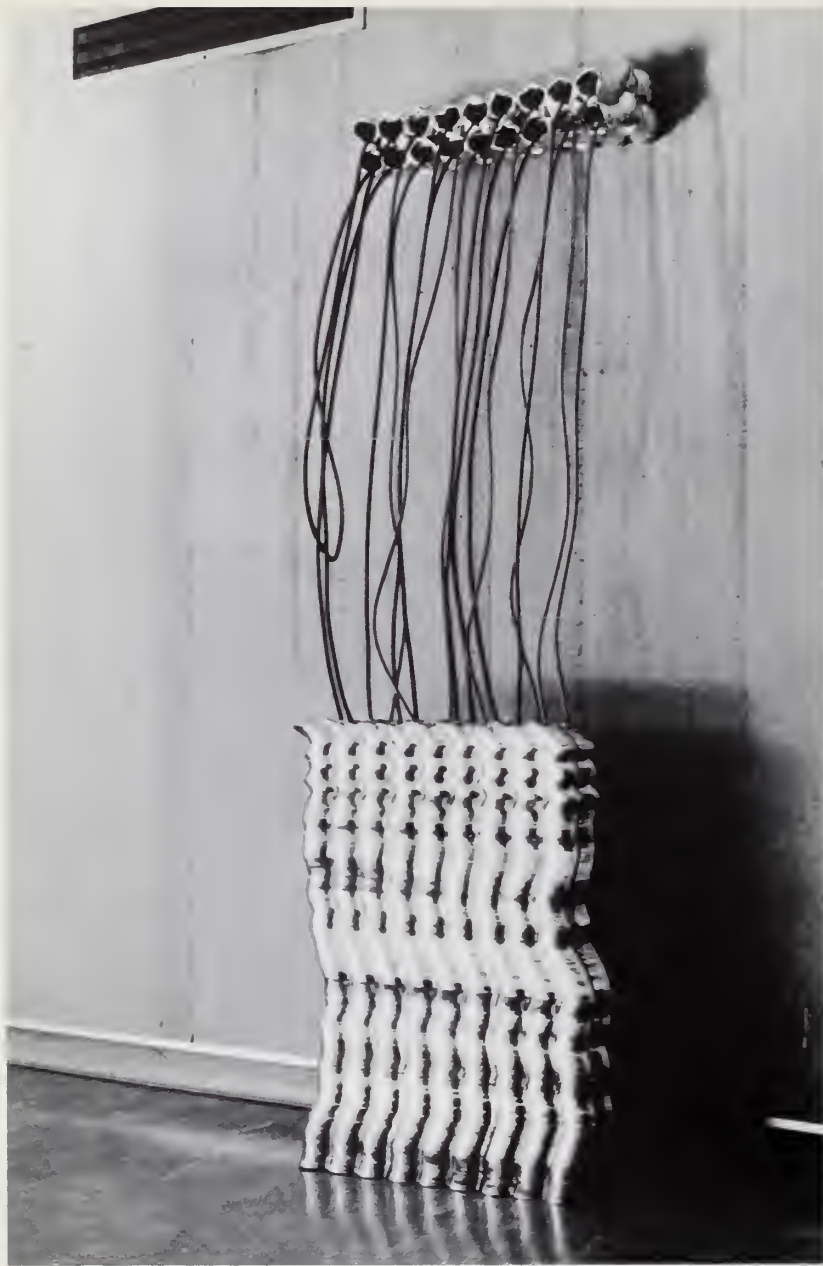

Walter McNamara Soft Ware with Non-Tongue

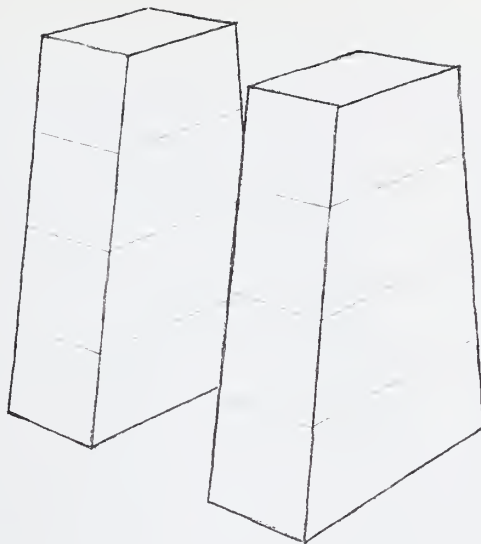

CONST. $\frac{3}{4}$ FIR PLYWOOD, PAINTED
WHITE. TOTAL 8 PARTS.
JOHN MCCRACKEN 1968

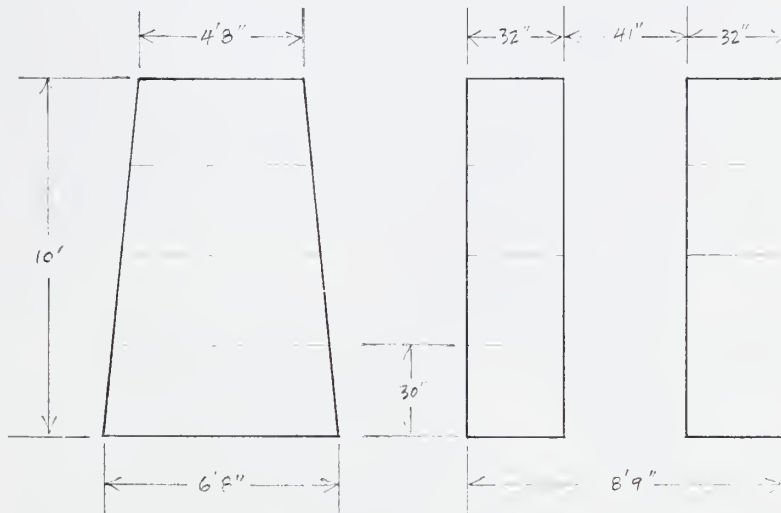

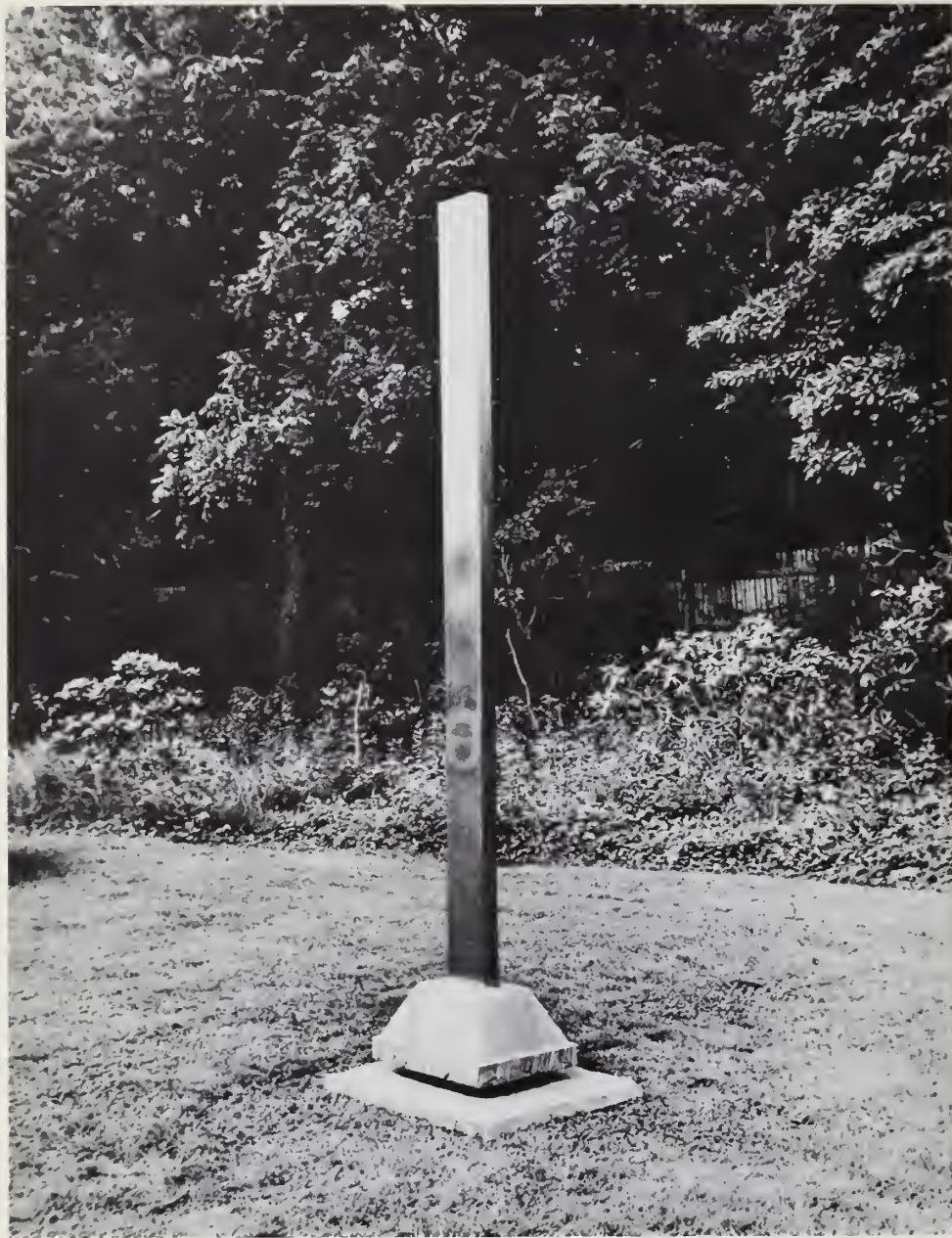

Barnett Newman Here III



Clement Meadmore U Turn

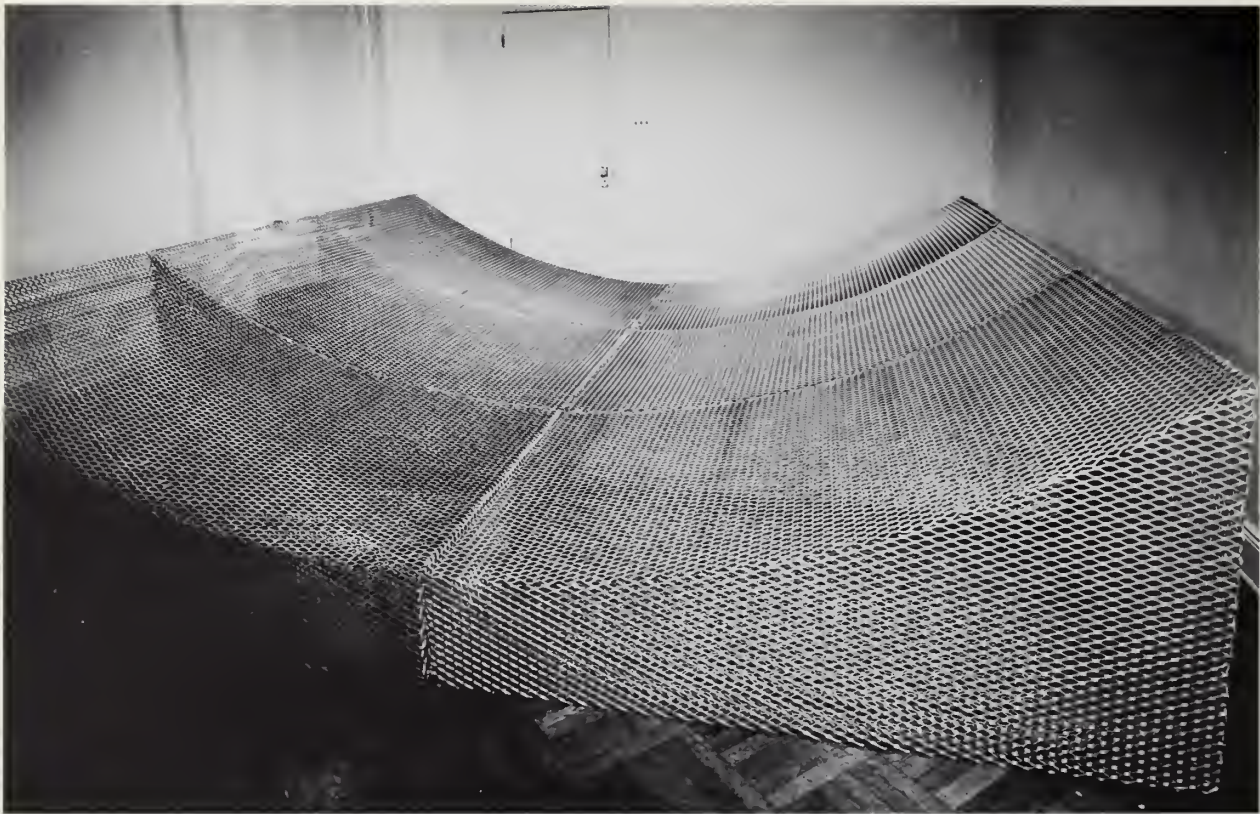

Robert Morris Untitled



Minoru Niizuma Windy Wind

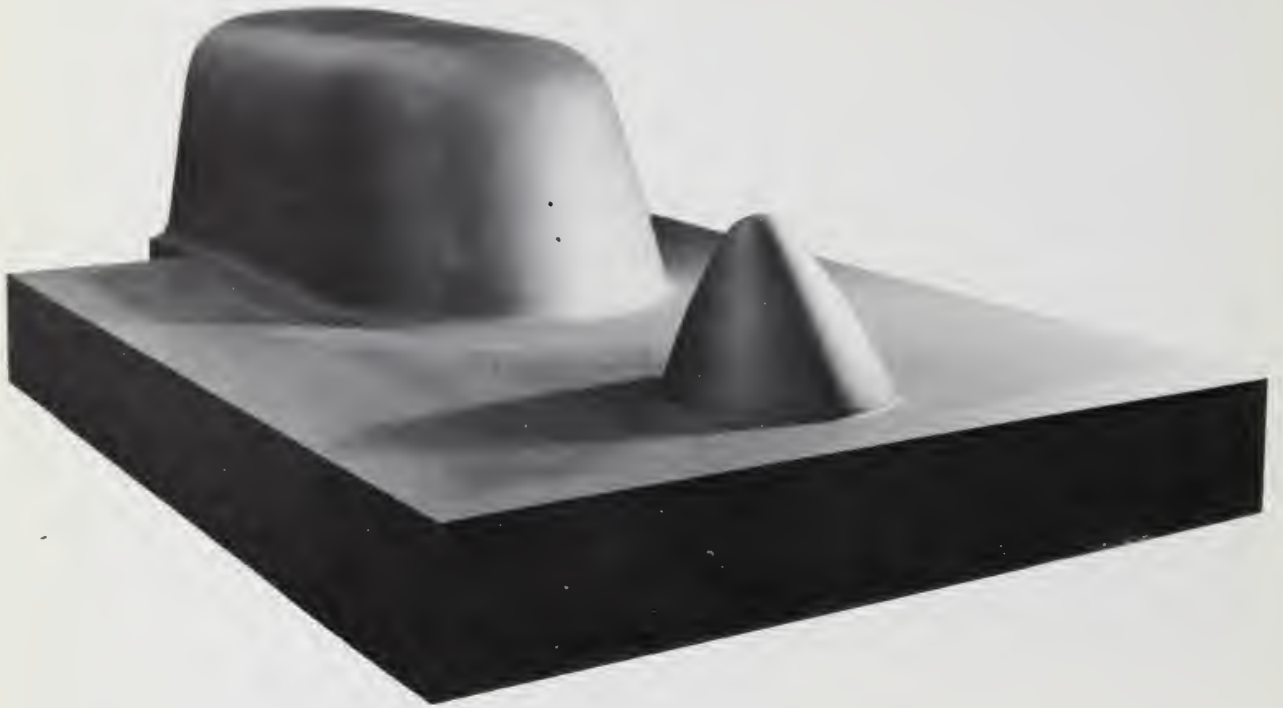

Harold Paris Conversation on a Black Afternoon: April 4, 1968, 6:01 P.M.

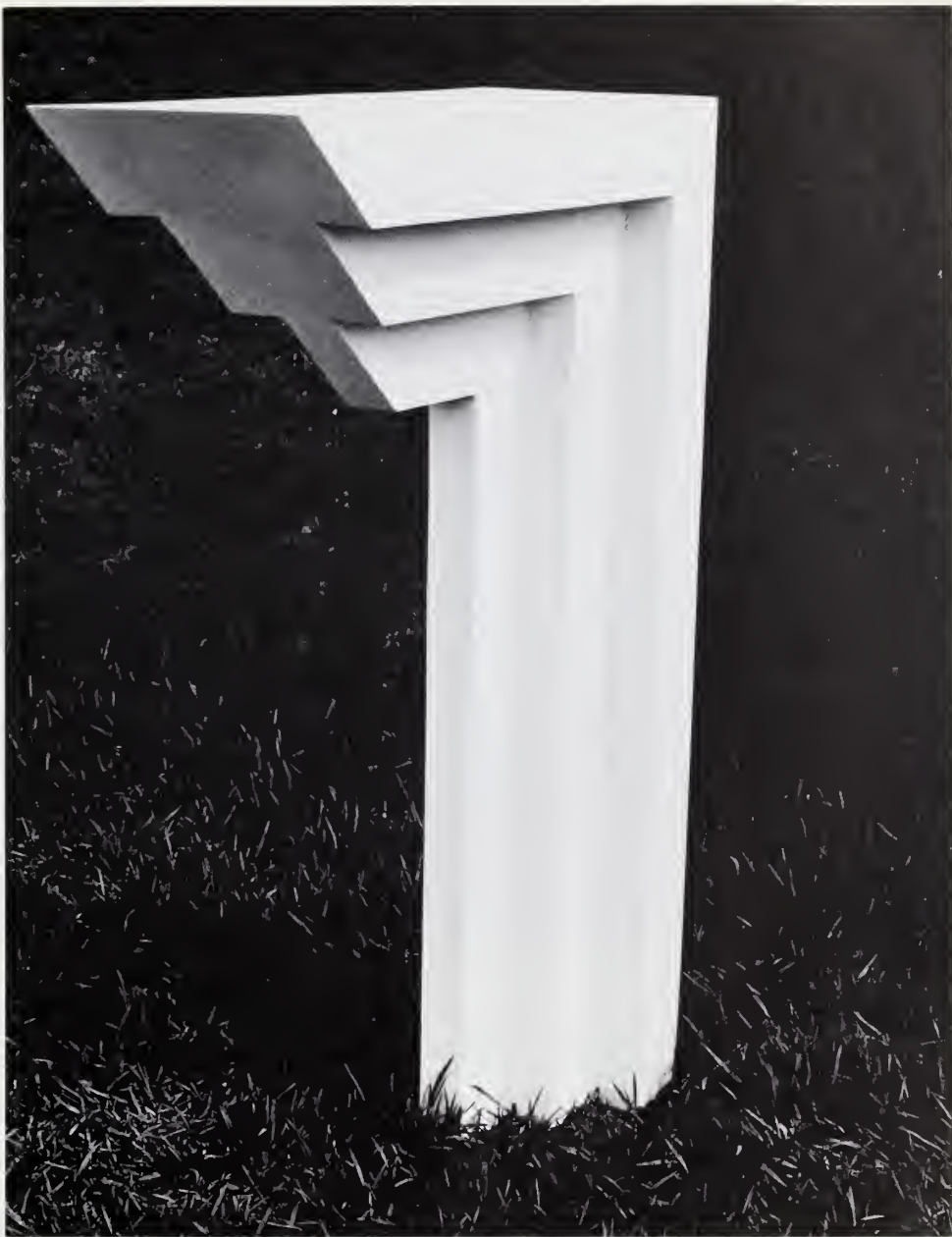

Carlos Ramos Untitled



Kenneth Price R. G. Violet

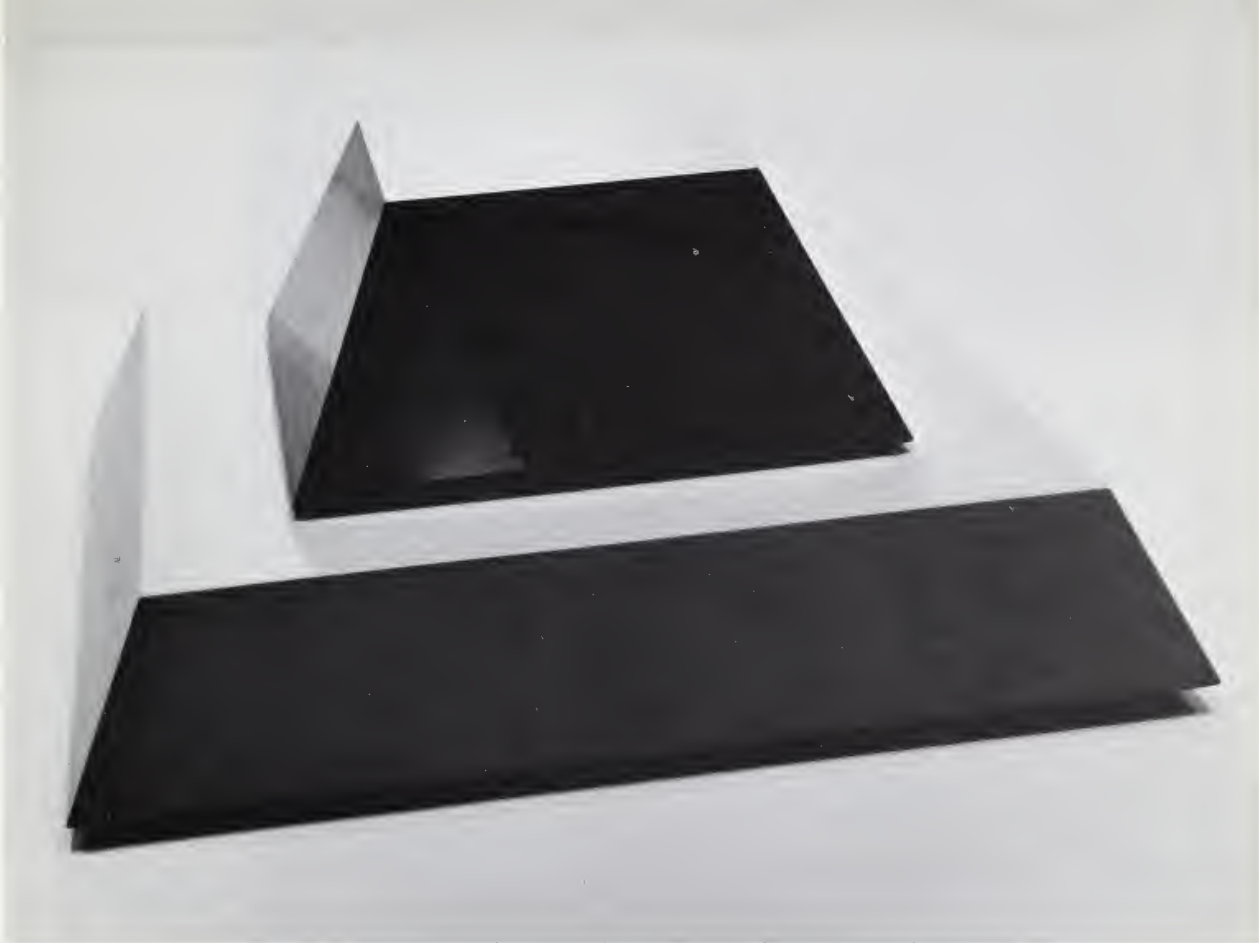

James Reineking Untitled Sitting Object / 2nd Edition



Larry Rivers Cropped Blue Bed

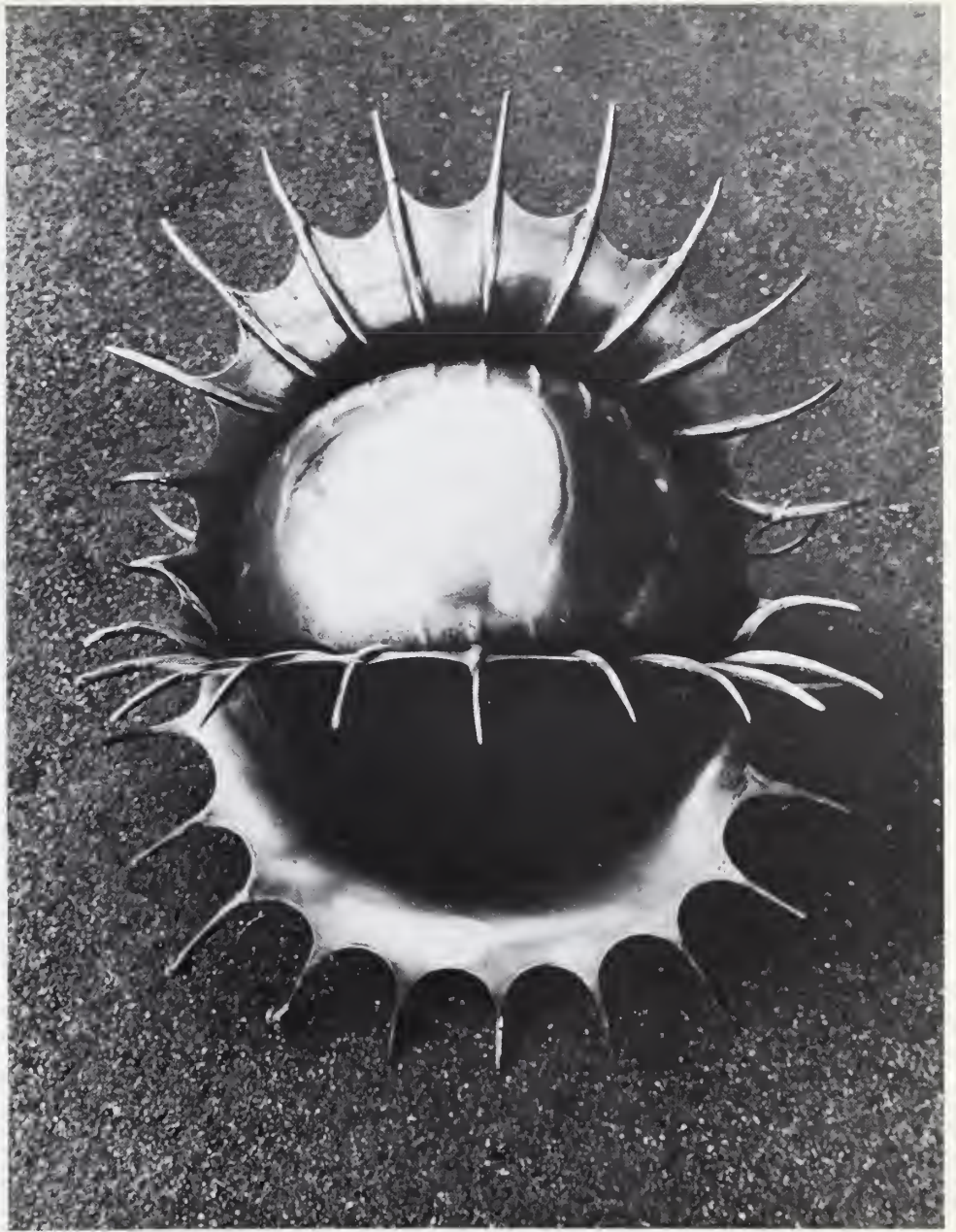

Henry Rollins The Sun



William Sellers Twist



Jason Seley Hanover II

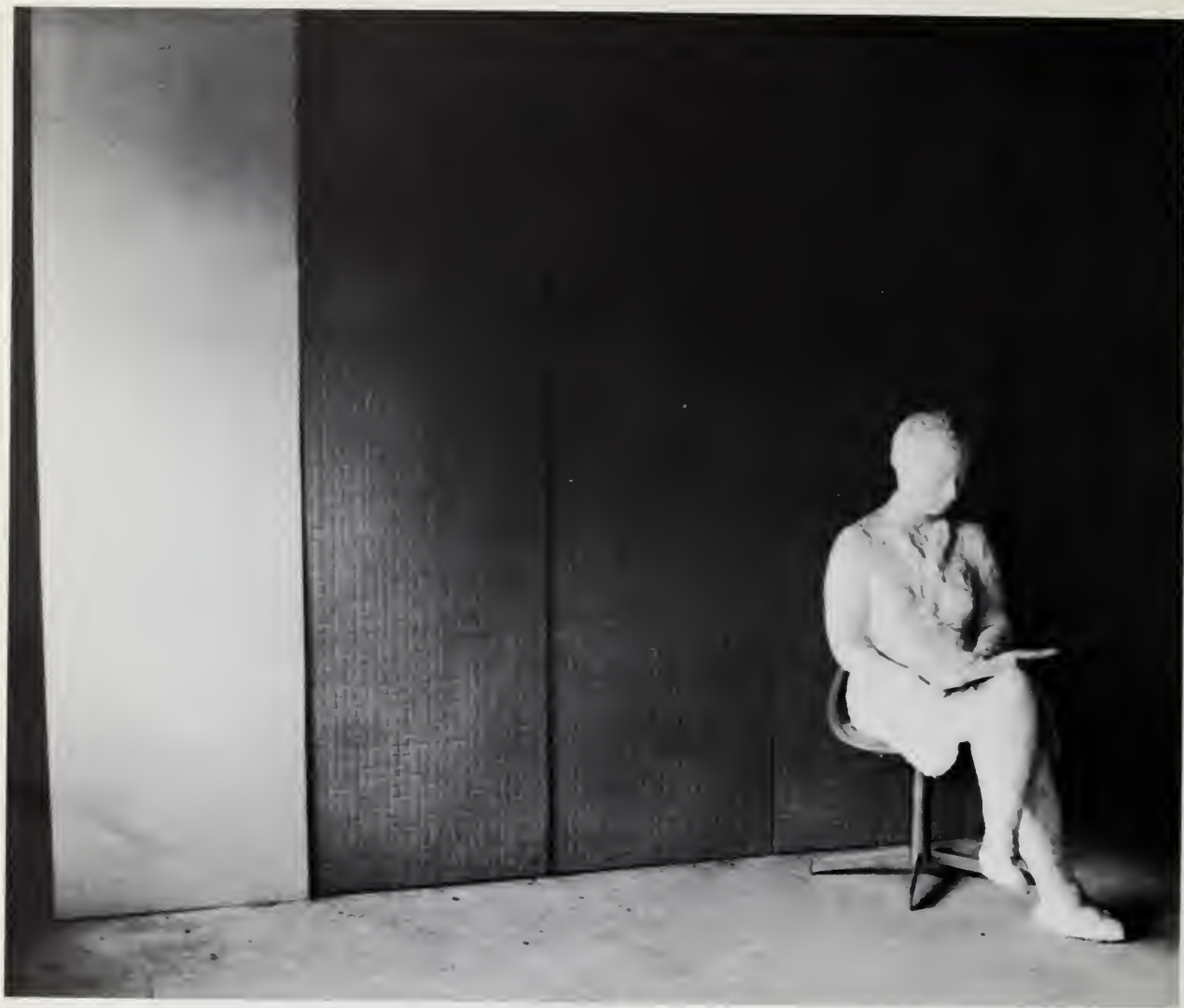

George Segal Laundromat

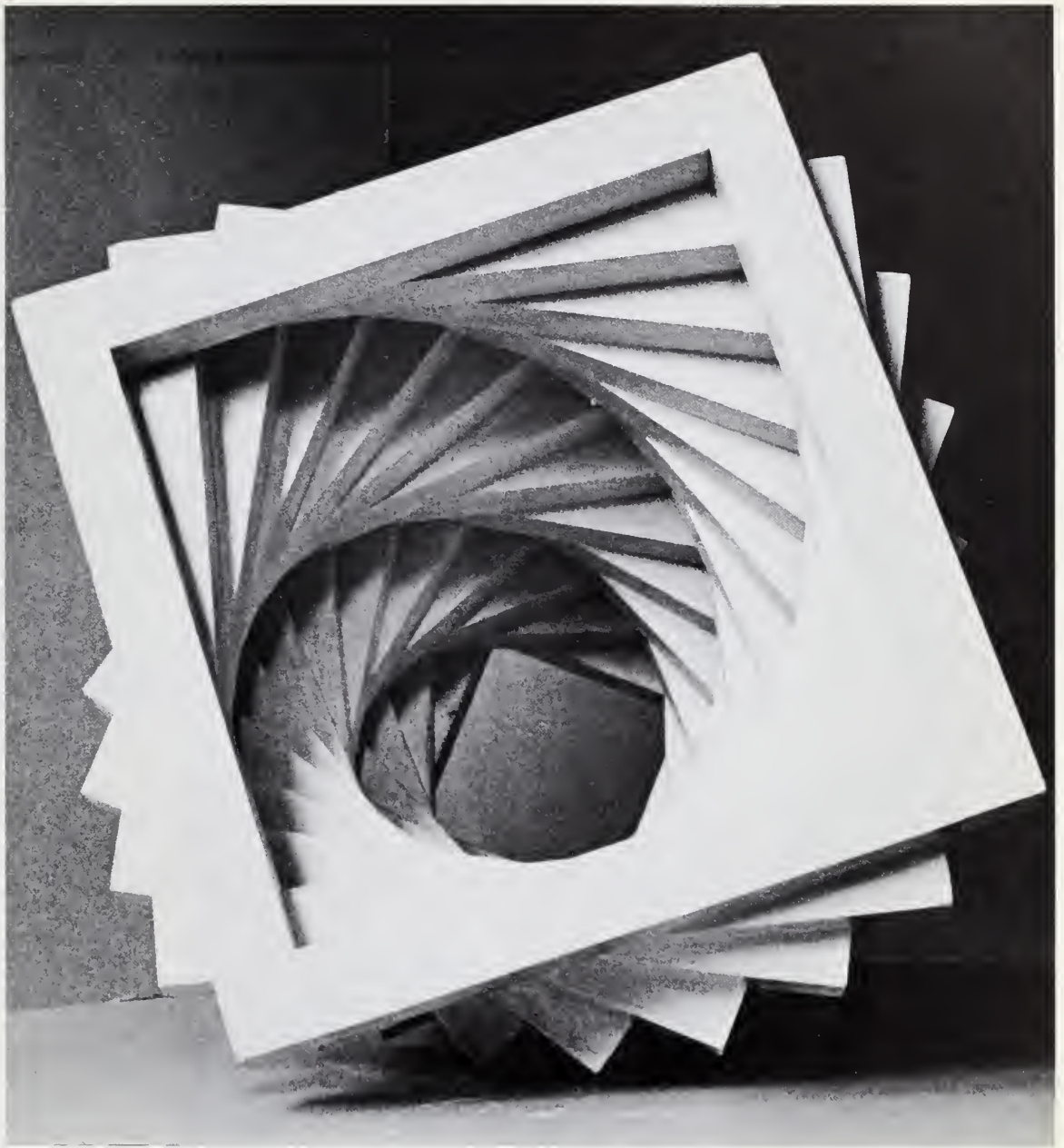

George Sugarman Square Spiral



Richard Serra Slow Roll for Philip Glass

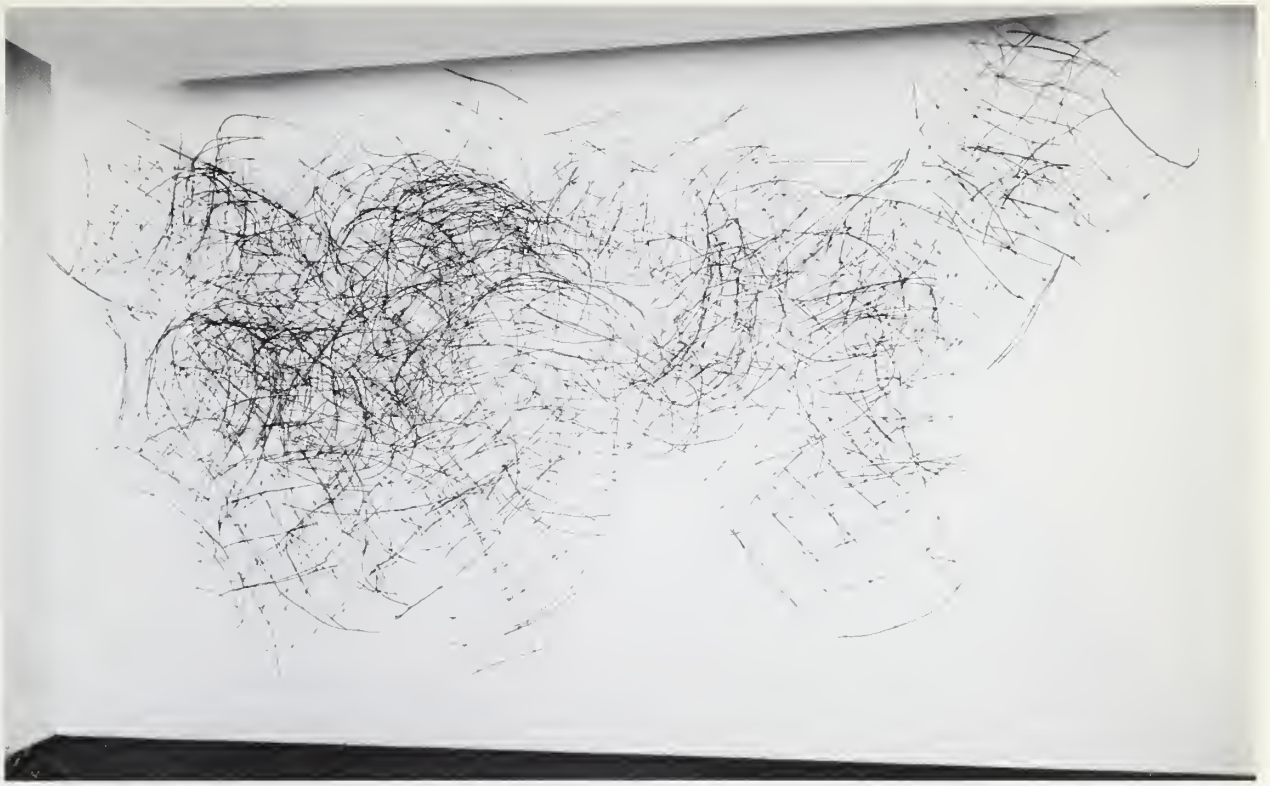

Alan Saret True Jungle: Canopy Forest



Bernard Rosenthal Odyssey



Julius Tobias Interior Space #3

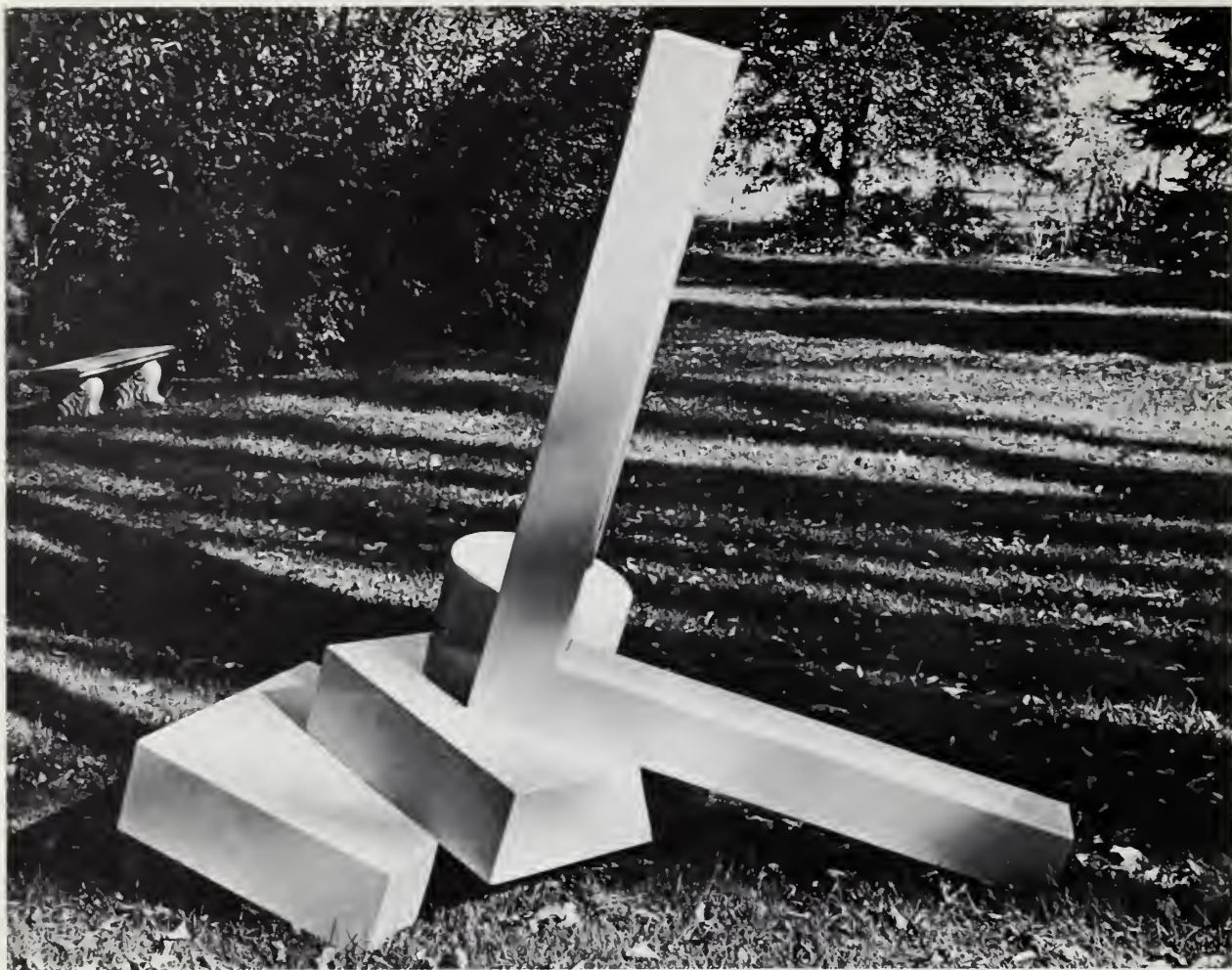

Michael Todd Untitled



Richard van Buren

Untitled



David Weinrib Son

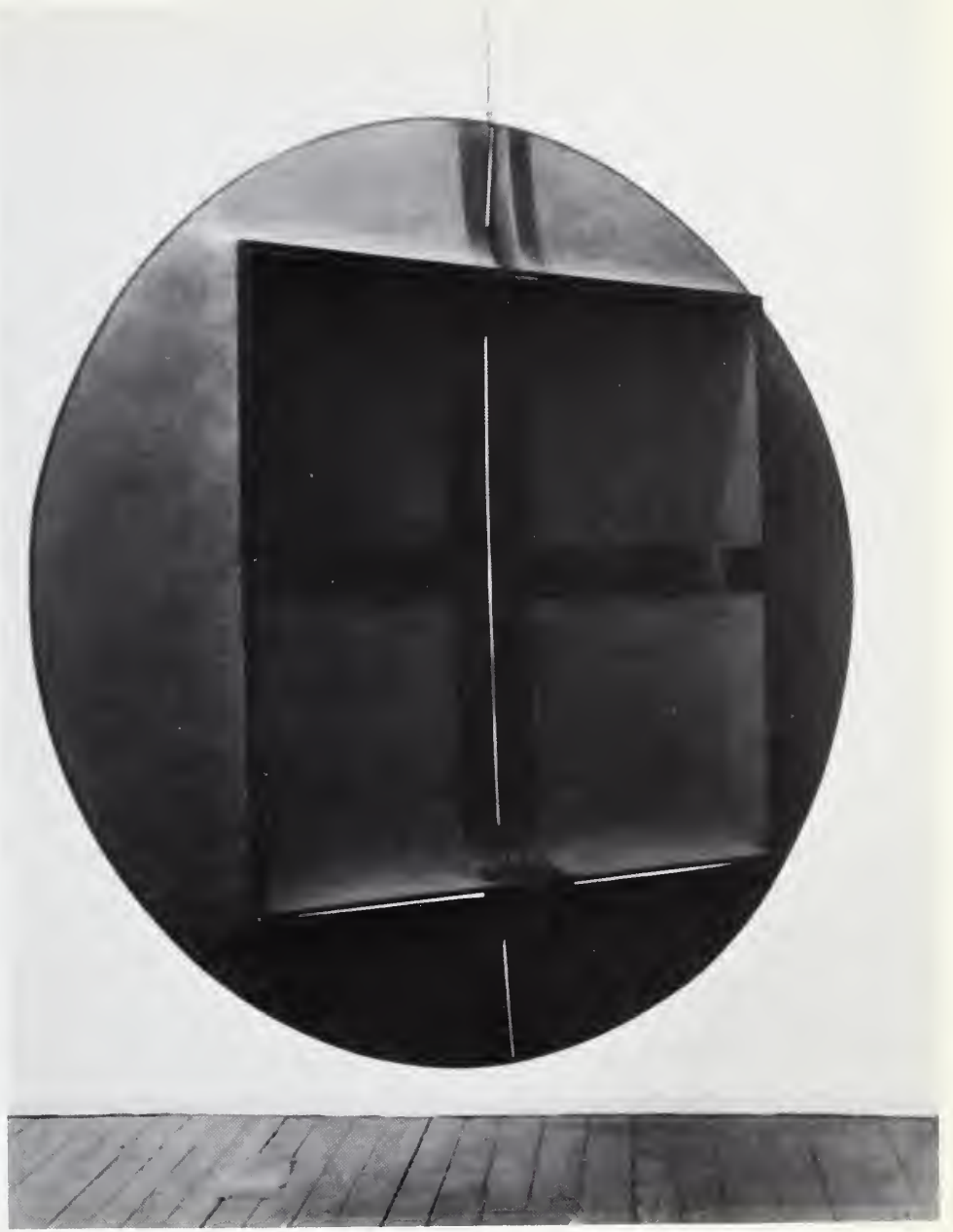

James Wines Disc and Square



Gary Wojcik Snaker Ray

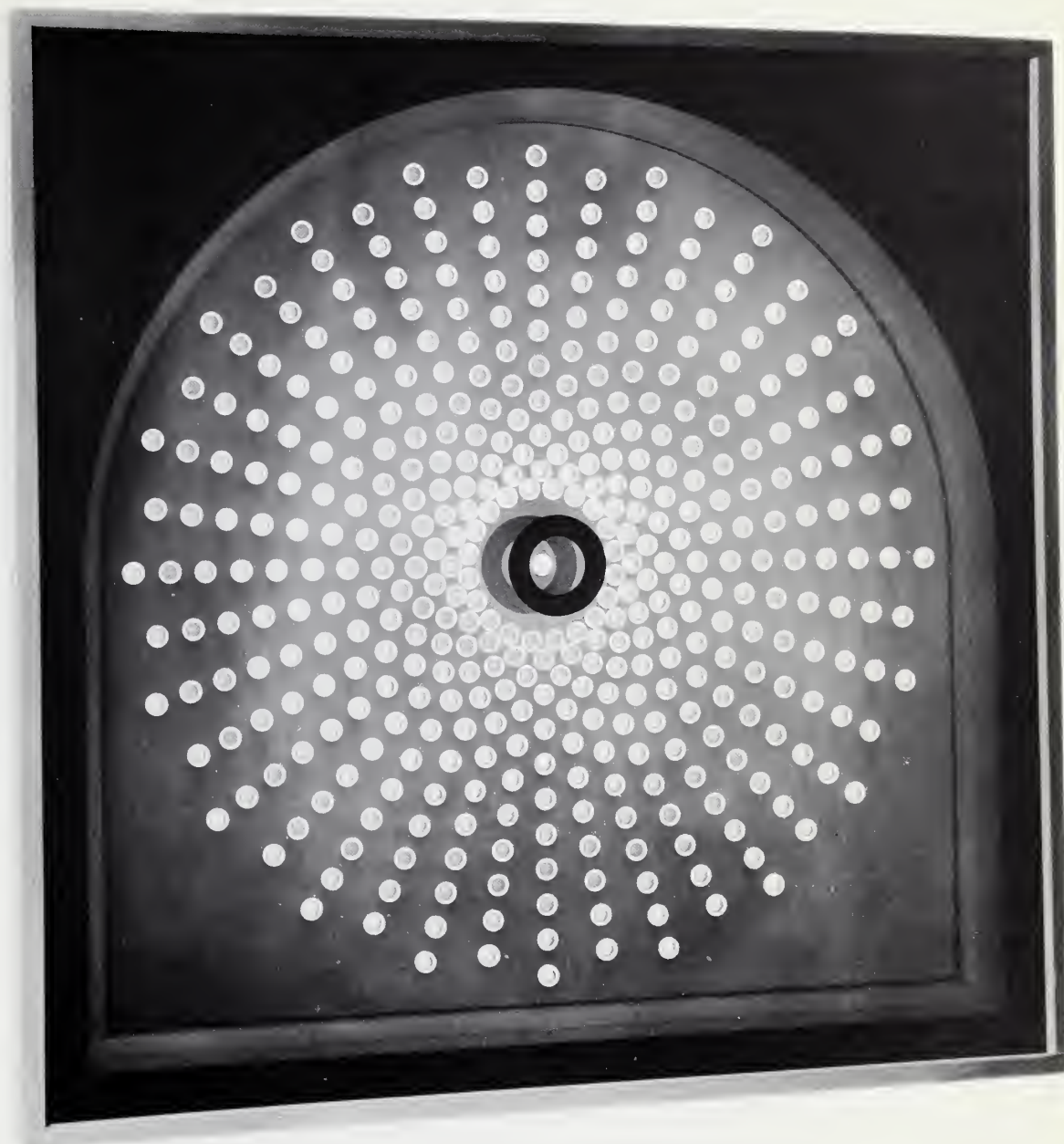

John Willenbecher Spheremusic No. 5



Tom Wesselmann Seascape Number 5

