

Model WT-5300A Patient Warming System

Service Manual



© 2011 Nellcor Puritan Bennett LLC. All rights reserved.

To obtain warranty information contact your local Nellcor representative.

Table of Contents

Safety Information.....	9
Overview	9
Warnings	9
Cautions.....	11
Introduction.....	13
Overview	13
Intended Use	13
Manual Availability.....	13
Background Information	13
Safety Features.....	14
Customized Warming Therapy	14
Automatic Temperature Stepdown.....	14
Automatic Over Temperature Shutdown	14
Alarms	15
HEPA Filter	16
Wheel Locks	16
Symbols.....	17
Description of the Warming System	17
Routine Maintenance	21
Overview	21
HEPA Filter Replacement.....	21
Power Cord Replacement.....	24
Nozzle Replacement.....	25
Cleaning the Warming Unit	26
Performance Verification.....	27
Overview	27
Power Fail / Start Alarm Check.....	27
Thermostat Protection Check.....	28
Output Temperature Check	31
Safety Tests.....	33
Repair.....	35
Overview	35
Filter Cover Assembly Replacement	36
Separating the Front and Rear Covers.....	38
Rejoining the Front and Rear Covers.....	41
Front Cover Assembly Replacement	42
Control PCBA Replacement.....	50
Heater Assembly Replacement.....	54
Hose Replacement	65
Duct Adapter Assembly Replacement	67
Rear Cover Assembly Replacement.....	72

Spare Parts & Accessories	87
Overview	87
Ordering Information.....	87
Replacement Parts and Accessories	90
Manual Availability.....	90
Packing for Shipment	91
Overview	91
Returning the Warming Unit	91
Repacking in Original Carton.....	91
Repacking in a Different Carton.....	93
Specifications	95
Overview	95
Warming System Specifications	95
Transport and Shipping in Shipping Container	96
Compliance.....	96
Manufacturer’s Declaration	96
Electromagnetic Compatibility (EMC).....	97
Electromagnetic Emissions.....	97
Electromagnetic Immunity.....	97
Ground Integrity Test	99
Earth Leakage Current Test.....	100
Enclosure Leakage Current Test.....	100
.....	100
Principles of Operation	101
Overview	101
Control Panel	101
Main Circuit Board.....	102
DC Power Supply Circuit.....	102
Control Logic Circuit.....	103
Automatic Temperature Stepdown.....	103
Alarm Drive Circuits.....	103
Temperature Control Circuit.....	104
LCD Hour Meter.....	105
AC Power Section	105
Blower	105
Heater.....	106
Thermostat Protection	106
Over-Temperature Test Port	106

List of Figures

Figure 1: Cart Wheel Lock.....	16
Figure 2: Front View.....	18
Figure 3: Back View.....	19
Figure 4: Operating Hours Meter.....	22
Figure 5: Filter Cover Screws.....	22
Figure 6: HEPA Filter and Power Cord Strain Relief.....	23
Figure 7: Power Cord Routing.....	24
Figure 8: Over-Temperature Test Port.....	29
Figure 9: WT-5300A Boost Temperature Setting.....	29
Figure 10: Warning Light.....	30
Figure 11: Output Temperature Test Setup.....	32
Figure 12: Temperature Selection.....	32
Figure 13: Ground Stud.....	33
Figure 14: Power Cord.....	37
Figure 15: Power Cord Routing.....	37
Figure 16: Filter Cover Screws.....	38
Figure 17: Power Cord.....	39
Figure 18: Power Cord Routing.....	39
Figure 19: Cover Screw Locations.....	40
Figure 20: Separated Covers.....	40
Figure 21: Cover Screw Locations.....	41
Figure 22: Cable Harness Bundle Ties.....	43
Figure 23: Front Cover Assembly.....	43
Figure 24: Power Switch Clips and Wires.....	44
Figure 25: Cable Disconnect.....	45
Figure 26: Control PCB Screws.....	45
Figure 27: Control PCB Lights.....	46
Figure 28: Control PCB Screws.....	46
Figure 29: Cable Connections.....	47
Figure 30: Power Switch Clips and Wires.....	47
Figure 31: Front Cover Assembly Component Locations.....	48
Figure 32: Equipotential Ground Stud Wiring.....	48
Figure 33: Cable Harness Bundle Ties.....	49
Figure 34: Control PCB Connections.....	50
Figure 35: Control PCB Screws.....	51
Figure 36: Control PCB Relay Assembly Removal.....	51
Figure 37: Control PCB Lights.....	52
Figure 38: Control PCB Screws.....	52
Figure 39: Cable Connections.....	53
Figure 40: Cable Harness Bundle Ties.....	53
Figure 41: Filter Removal.....	55
Figure 42: Blower Assembly Screws.....	55
Figure 43: Cable Harness Bundle Ties.....	56
Figure 44: Front Cover Assembly.....	56
Figure 45: Duct Adapter Placement.....	57
Figure 46: Blower Motor Removal.....	58
Figure 47: Blower Assembly Clips.....	58
Figure 48: Rubber Gasket.....	59

Figure 49: Heater Assembly	59
Figure 50: Heater Assembly Installation	60
Figure 51: Rubber Gasket	61
Figure 52: Blower Assembly Clips.....	61
Figure 53: Duct Adapter Placement	62
Figure 54: Blower Assembly Screws	63
Figure 55: Cable Harness Bundle Ties	63
Figure 56: Filter Installation.....	64
Figure 57: Filter Cover Installation	64
Figure 58: Hose Attachment.....	66
Figure 59: Thermistor Silicone	68
Figure 60: Thermistor Removal	68
Figure 61: Duct Adapter Removal	69
Figure 62: Duct Adapter Placement	70
Figure 63: Thermistor Position Within Duct Adapter.....	70
Figure 64: Filter Cover Screws.....	73
Figure 65: Filter Removal	73
Figure 66: Separated Covers	74
Figure 67: Front Cover Assembly.....	74
Figure 68: Cable Disconnect	75
Figure 69: Thermistor Cable Removal	76
Figure 70: Blower Assembly Screws	76
Figure 71: Blower Capacitor	77
Figure 72: Blower Motor Removal	77
Figure 73: Blower Assembly Clips.....	78
Figure 74: Rubber Gasket	78
Figure 75: Heater Assembly	79
Figure 76: Heater Assembly Installation	79
Figure 77: Rubber Gasket	80
Figure 78: Blower Installation	80
Figure 79: Blower Screws	81
Figure 80: Thermistor Cable Installation.....	81
Figure 81: Capacitor Installation	82
Figure 82: Cable Connections	82
Figure 83: Front Cover Assembly.....	83
Figure 84: Equipotential Ground Stud Wiring	84
Figure 85: Cable Harness Bundle Ties	84
Figure 86: Filter Installation.....	85
Figure 87: Filter Cover Installation	85
Figure 88: Spare Parts (Sheet 1).....	89
Figure 89: Spare Parts (Sheet 2).....	90
Figure 90: Packing the Warming Unit in Original Carton.....	92
Figure 91: Control Panel	101
Figure 92: Hour Meter	105
Figure 93: Warming Unit Schematic (Sheet 1).....	107
Figure 94: Warming Unit Schematic (Sheet 2).....	108

List of Tables

Table 1: Symbols on the Warming Unit	17
Table 2: Equipment Required for HEPA Filter Replacement	21
Table 3: Equipment Required for Power Cord Replacement.....	24
Table 4: Equipment Required for Thermostat Protection Check	28
Table 5: Equipment Required for Output Temperature Check	31
Table 6: Filter Cover Assembly Components	36
Table 7: Tools Required for Replacing Filter Cover Assembly	36
Table 8: Tools Required for Separating Front and Rear Covers	38
Table 9: Filter Cover Assembly Components	42
Table 10: Tools Required for Replacing Front Cover Assembly	42
Table 11: Tools Required for Replacing Control PCB	50
Table 12: Heater Assembly Components	54
Table 13: Tools Required for Replacing Heater Assembly	54
Table 14: Hose Assembly Components	65
Table 15: Tools Required for Replacing Hose Assembly	65
Table 16: Duct Adapter Assembly Components	67
Table 17: Tools Required for Replacing Duct Adapter Assembly	67
Table 18: Rear Cover Assembly Components	72
Table 19: Tools Required for Replacing Rear Cover Assembly	72
Table 20: Spare Parts and Accessories	88
Table 21: System Specifications	95
Table 22: Shipping Container Specifications	96
Table 23: Compliance Standards	96
Table 24: Electromagnetic Emissions Guidelines	97
Table 25: Electromagnetic Immunity Guidelines.....	97
Table 26: Recommended Separation Distances.....	99
Table 27: Earth Leakage Current Test	100
Table 28: Enclosure Leakage Current Test.....	100

Page Left Intentionally Blank

Safety Information

Overview

This chapter contains safety information requiring users to exercise appropriate caution when servicing the WarmTouch™ Model WT-5300A patient warming system.



The WARNING symbol identifies warnings.

Warnings alert the user to potential serious outcomes, such as death, injury, or adverse events to the patient or user.



The CAUTION symbol identifies cautions.

Cautions alert the user to exercise care necessary for the safe and effective use of the warming system.



The NOTE symbol identifies notes.

Notes contain important information that may otherwise be overlooked or missed.

Warnings



WARNING

Possible explosion hazard. Do not use the device in the presence of flammable anesthetics.



WARNING

Possible electrical shock hazard. To reduce the risk of electrical shock do not remove the back case. Servicing is only to be done by qualified personnel.



WARNING

Possible electric shock hazard. Grounding reliability can be achieved only when the warming system is connected to a suitable mains outlet.



WARNING

Possible fire hazard. Prevent the blanket material from coming into contact with a laser or an electrosurgical active electrode; rapid combustion could result.



WARNING

Possible burn hazard. Do not apply heat directly to open wounds. All patient's wounds should be covered while using the warming system.



WARNING

Possible patient burns. Use caution and consider discontinuing use on patients during vascular surgery when an artery to an extremity is clamped. Do not apply the warming system to ischemic limbs.



WARNING

Possible patient burns. Use caution and monitor closely if used on patients with severe peripheral vascular disease.



WARNING

If a malfunction occurs in the warming system, discontinue use. Notify your sales/service center of the malfunction. The unit must be serviced by an authorized service technician.



WARNING

No free-hosing. Keep hose nozzle connected to a WarmTouch™ blanket at all times or thermal injury may occur.



WARNING

WarmTouch CareDrape™ and CareQuilt™ blankets are for single patient use only.

**WARNING**

The warming system should not be operated in the presence of electromagnetic fields that are greater than 3 volts/meter. This could cause shutdown of the warming system by the fail-safe function within the equipment.

**WARNING**

The warming system is not suitable for use during magnetic resonance imaging (MRI) scanning. The warming system may affect the MRI image.

**WARNING**

Continuously monitor the patient's temperature. Reduce the air temperature or discontinue therapy when normothermia is reached.

**WARNING**

The patient must be closely monitored for rewarming. Vasodilation and potential hypotension can occur. Use good judgment when selecting a temperature. If unsure of proper setting, consult with the attending physician.

**WARNING**

The use of accessories and power cables other than those specified may result in increased emission and/or decreased immunity of the warming system.

**WARNING**

Thermal injury may result if the warming system hose comes into contact with the patient.

**WARNING**

Using the warming system on transdermal medication patches may increase the rate of drug delivery, potentially causing harm to the patient.

**WARNING**

Before attempting to open or disassemble the warming system, disconnect the power cord from the AC power source.

Cautions

**Caution**

Federal (U.S.A.) law restricts the use of the warming system to sale by or on the order of a physician.



Caution

The warming system is fitted with an air filter; however, airborne contamination should be considered when using the warming system.



Caution

If the warming system is mounted on the intravenous (IV) pole, it should be installed with the top of the unit's handle less than 76 cm (30 inches) above the floor to prevent the IV pole from tipping over.



Caution

The institution should follow local governing ordinances and recycling instructions regarding disposal or recycling of filter and device components or end of life of the product.



Caution

The HEPA filter **must** be changed every 2,000 hours of operation. Refer to the Routine Maintenance section for replacement procedures requiring a qualified technician.



Caution

Do not spray, pour, or spill any liquid on the warming unit, its accessories, connectors, switches or openings in the case.



Caution

Observe ESD (electrostatic discharge) precautions when working within the warming system.



Caution

Repairs to the warming system should only be accomplished by trained service technicians.



Caution

Ensure that the patient is dry or the warming system may be ineffective.

Introduction

Overview

This chapter provides an introduction to the WarmTouch™ Model WT-5300A patient warming system.

Intended Use

The WarmTouch™ Model WT-5300A patient warming system (warming unit and blanket) is intended for prevention and treatment of hypothermia, for example, with the surgical patient, the patient in the pre-operative holding area, the pregnant woman who shivers during epidural anesthesia due to hypothermia, or any patient who is uncomfortable anywhere in the cold critical care environment.

Manual Availability

The most recent revision of this manual is available on the Internet at:

<http://www.nellcor.com/serv/manuals.aspx>

Background Information

There are numerous ways of warming your patient, from cotton blankets to water mattresses. Research has shown that low temperatures surrounding the patient are a major factor contributing to hypothermia.^{1,2} The warming system covers the patient with warm air and actively transfers heat across the skin. The result is to achieve normothermia.

¹ Morris RH, Wilkey BR. "The Effects of the Ambient Temperature on Patient Temperature During Surgery Not Involving Body Cavities." *Anesthesiology* 32:102-107, 1970.

² Morris RH. "Influence of Ambient Temperature on Patient Temperature During Intra-abdominal Surgery." *Annals of Surgery* 173:230-233, 1971.

In creating this warm customized pocket of air around the hypothermic patient, it is important to note that stagnant air, even if it is warm, does not work as an effective heat transfer medium. Stagnant air acts as an insulator, preventing the boundary layer of molecules next to the skin surface from transferring heat.

Forced air warming causes warmed air molecules to flow over cooler skin surface. It is this active flow of warmed molecules that acts as a heat transfer medium. With the warming system, air is warmed and delivered into a lightweight blanket (*CareQuilt* or *CareDrape* blanket) that rests over or under the patient. The *CareQuilt* and *CareDrape* blankets have many small perforations on the underside that allow air to exit the blanket and surround the patient.

Safety Features

The warming system is designed to give healthcare professionals more control over the patient's core body temperature. There are several safety features of the warming system which make it safe and appropriate for such use.

Customized Warming Therapy

Clinicians select temperature range setting at the onset of warming therapy to help ensure the appropriate setting is selected for every patient.

Automatic Temperature Stepdown

The warming system provides a 45-minute temperature stepdown feature. When in Boost mode, blower temperature will automatically drop to the High temperature setting after each 45 minutes of use. The temperature may be reset to Boost Mode at any time by selecting the Boost temperature setting on the control panel to start another 45-minute cycle.

Automatic Over Temperature Shutdown

The automatic temperature controller and two back-up systems help to ensure temperature will not reach excessive levels. If necessary, the control system automatically turns off the heater element when the blower outlet temperature rises to between 47° C and 50° C, illuminates the warning light,

and sounds an audible alarm. The warming system heater will start producing heat when the warming system temperature drops to between approximately 34° C and 37° C. A yellow warning light illuminates whenever the control system identifies an over-temperature condition.

Alarms

The WarmTouch control circuit manages and monitors operation of the patient warming system. Should the control circuit encounter a failure condition, it reports failures using both visual and audible alarms. The visual alarm is a yellow warning indicator on the control panel that lights at power on, upon power restoration following power failure, and whenever the control system identifies an alarm condition. The audible alarm sounds intermittently or continuously, depending on the alarm condition. In either case, investigate immediately.

The WarmTouch control circuit recognizes two failure conditions.

1. **Power On/Power Fail Alarm** — This condition causes an intermittent audible alarm and continuous visual alarm. It appears at power on and after power failure, indicating the operator must select the desired temperature. Upon selection of a temperature key, the system cancels the alarm and the blower operates at the desired temperature.
2. **Over-temperature Alarm** — This condition causes a continuous audible alarm and a flashing visual alarm. It appears when reaching the temperature safety limit, and the control system turns off the heater. Once the system air temperature returns to a safe operating temperature of between 34°C and 37°C, the heater will turn back on.

If the control system determines the heater again exceeds the safety limit, the warming system alarms once more. Take the warming system out of service for repair by a qualified service technician.

If a power failure occurs while the warming system is in the over-temperature fault condition, and the warming system is still in the over-temperature fault condition when power is restored, both continuous audible and visual alarms will activate. In this instance, the over-temperature fault cannot be cleared. Take the warming system out of service for repair by a qualified service technician.



Note:

The Power Fail/Start Alarm is only found on WT-5300A warming units containing a Control PCBA with part number GR100307.

HEPA Filter



Caution

The HEPA filter must be changed every 2,000 hours of operation. Refer to the Routine Maintenance section for replacement procedures requiring a qualified technician.

The system's High Efficiency Particulate Air Filter is 99.97% efficient at 0.3-micron particle size.

Wheel Locks

The cart is equipped with two wheel locks. The wheel locks prevent the cart from moving while in use. The wheel locks must be released when moving the cart. Press the wheel lock arm down to lock the wheel. Lift the wheel lock arm to release the wheel lock. See Figure 1.









Figure 1. Cart Wheel Lock

Symbols

The symbols identified in Table 1 are the symbols used on the warming unit.

Table 1. Symbols on the Warming Unit

	Attention symbol, consult accompanying documentation.
	Do not direct air from the hose to the patient (free-hosing); use hose only with warming blankets.
	Dangerous voltage
Class 1 	Protection Class I Protection Type BF
	Date of manufacture
	Visual and audible alert

Description of the Warming System

The warming unit (Figure 2 and Figure 3) and *CareQuilt™* and *CareDrape™* blankets are intended for prevention and treatment of hypothermia. For example, use the warming system with the surgical patient, the patient in the preoperative holding area, the pregnant woman who shivers during epidural anesthesia due to hypothermia, or any patient who is uncomfortable anywhere in the cold critical care environment.



- | | | | |
|---|--------------|---|---------------|
| 1 | Hose | 4 | Power Cord |
| 2 | Power Switch | 5 | Hours Meter |
| 3 | Nozzle | 6 | Control Panel |

Figure 2. Front View

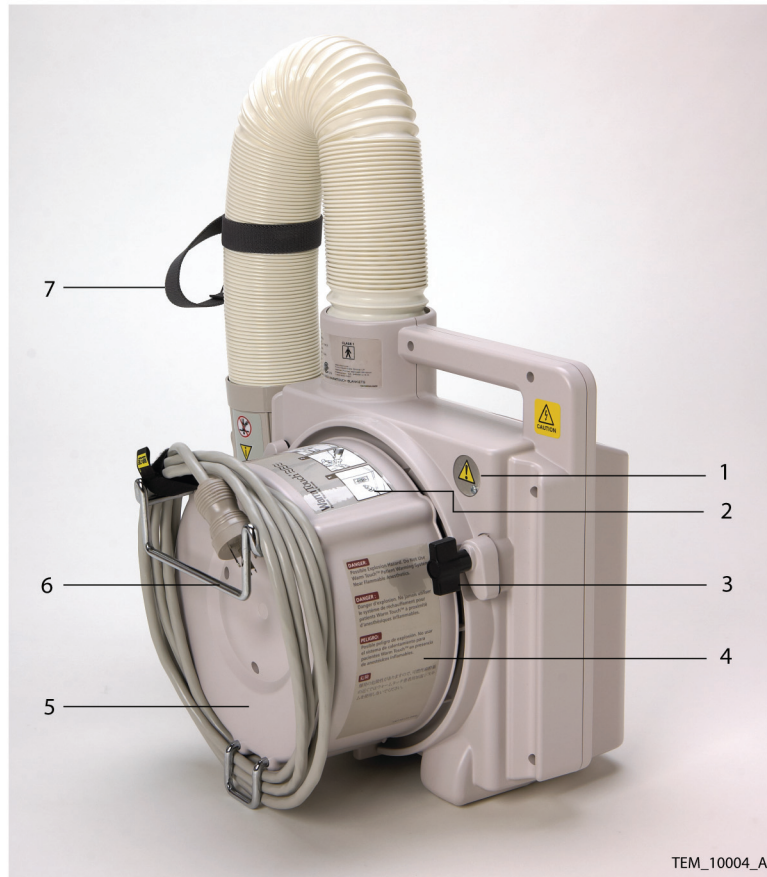

- | | | | |
|---|----------------------------|---|------------------------|
| 1 | Over-Temperature Test Port | 5 | Filter Cover |
| 2 | Instruction Label | 6 | Bed Hook Bracket |
| 3 | Blower Cart Clamp | 7 | Nozzle Strap with Clip |
| 4 | Warning Label | | |

Figure 3. Back View

Page Left Intentionally Blank

Routine Maintenance

Overview

This chapter provides routine maintenance procedures for the WarmTouch™ Model WT-5300A patient warming system.



Caution

The institution should follow local governing ordinances and recycling instructions regarding disposal or recycling of filter and device components or end of life of the product.

HEPA Filter Replacement

The warming system filter **must** be replaced after every 2,000 hours of use. Contact Nellcor’s Customer Service Department (1.800.635.5267, press 3 in the U.S.A.) or your local Nellcor representative to purchase new filters. The correct filter will be sent to your hospital for installation.



Caution

Only qualified hospital personnel should replace the air filter.

Table 2. Equipment Required for HEPA Filter Replacement

Equipment	Description / Use
Phillips screwdriver	#2 / Removing screws
Replacement filter	P/N 505-2200
Flat blade screwdriver	Detaching power cord from filter cover



WARNING

Do not operate the warming system with the back cover removed.



Note:

To read the operating hours meter, the warming system must be running.

To replace the HEPA filter:

1. Write the date and total hours of operation of the warming system on the new filter label and warming system label. The operating hours meter is on the front of the warming system (see Figure 4).



Figure 4. Operating Hours Meter

2. Unplug the warming system.
3. Lay the warming unit on its front side so that the bottom of the warming unit is visible.
4. Unwrap the power cord from the filter cover.
5. Remove the filter cover screws. See Figure 5.

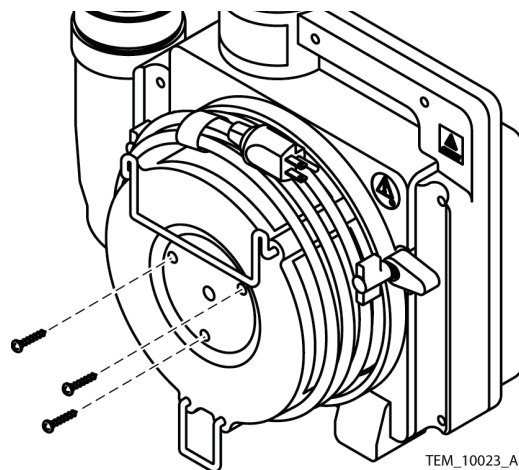

Figure 5. Filter Cover Screws

6. Unseat the power cord from the power cord routing bracket on the filter cover. If necessary, use the head of the flat blade screwdriver to separate the halves of the bracket sufficiently to allow unseating of the cord.
7. Remove the filter cover.
8. Remove the filter. See Figure 6.

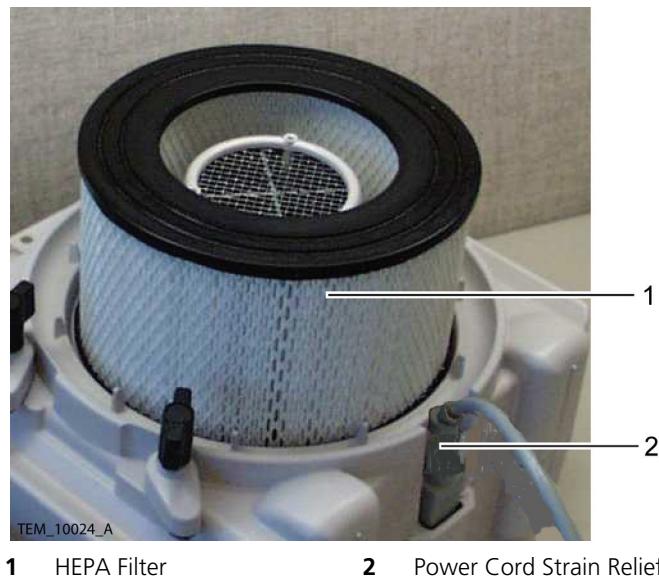

Figure 6. HEPA Filter and Power Cord Strain Relief

9. Place the new filter into the warming unit.
10. Ensure that the power cord's female connector is still fully inserted into the socket in the warming unit housing.
11. Place the filter cover on the case and reseal the power cable into the power cable routing bracket on the bottom of the cover.
12. Align the filter cover with the three screw holes in the filter and install the three screws holding the filter cover to the warming unit.
13. Attach the completed replacement filter label to the rear surface of the filter cover. If a replacement filter label is already present, cover it with the new label.

Power Cord Replacement

The warming system is equipped with a detachable power cord. If the power cord is damaged, contact your local Nellcor representative.



Caution

Only qualified hospital personnel should replace the power cord.

Table 3. Equipment Required for Power Cord Replacement

Equipment	Description / Use
Phillips screwdriver	#2 / Removing screws
Flat blade screwdriver	Detaching power cord from filter cover

To replace the power cord:

1. Unplug the warming system power cord from the AC outlet.
2. Lay the warming unit on its rear side so the bottom of the unit is visible.
3. Unwind the power cord from the filter cover.
4. Loosen the retaining bracket screws slightly, so that the retaining bracket can be pulled away from the power cord connector. See Figure 7.

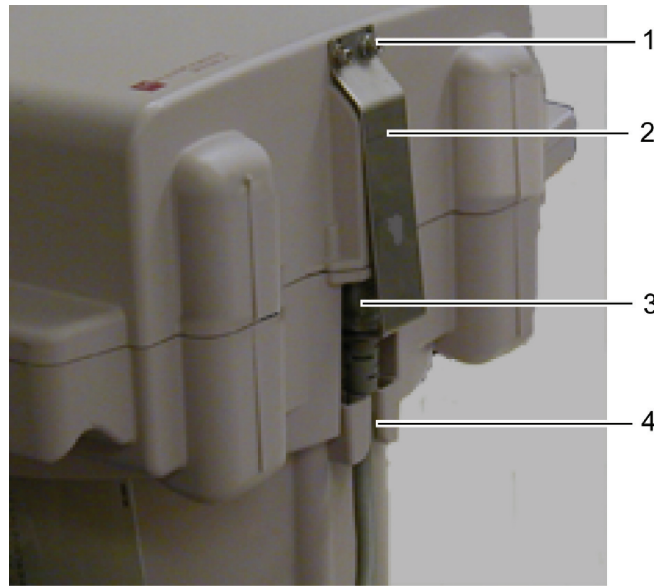

- | | | | |
|----------|--------------------------|----------|----------------------------|
| 1 | Retaining Bracket Screws | 3 | Power Cord Connector |
| 2 | Retaining Bracket | 4 | Power Cord Routing Bracket |

Figure 7. Power Cord Routing

5. Unseat the power cord from the power cord routing bracket (Figure 7, item 4) on the filter cover. If necessary, use the head of the flat blade screwdriver to separate the halves of the bracket sufficiently to allow unseating of the cord.
6. Disconnect the power cord connector (Figure 7, item 3) from its socket in the blower housing.
7. Connect the replacement power cord connector to the warming unit, making sure the connector is fully inserted into the socket in the warming unit housing.
8. Slide the power cord retainer bracket over the power cord connector and tighten the retainer bracket screws until snug.
9. Reseat the power cord into the power cord routing bracket. If necessary, use the head of the flat blade screwdriver to separate the halves of the bracket sufficiently to allow reseating of the cord.

Nozzle Replacement

If the nozzle is damaged, contact your Nellcor representative.

The only equipment required for this procedure is a flat blade screwdriver. The nozzle is held in place at its base by four clips on the hose assembly; make sure the screwdriver is long enough to reach inside the nozzle to the clips.

To replace the nozzle:

1. Insert the screwdriver blade into the nozzle, positioning it between one of the clips and the inner surface of the nozzle.
2. Use the screwdriver blade to push the clip in toward the center of the nozzle, while simultaneously pulling the nozzle away from the hose until the clip is disengaged from the base of the nozzle.
3. Repeat steps 1 and 2 to disengage the other three clips.
4. Remove the nozzle from the hose.
5. Put the replacement nozzle over the end of the hose.
6. Push the replacement nozzle down onto the hose until all four clips engage with the nozzle.

Cleaning the Warming Unit



Caution

Do not spray, pour, or spill any liquid on the warming unit, its accessories, connectors, switches, or openings in the case.

For surface-cleaning and disinfecting, follow your institution's procedures or the recommended actions below.

- **Surface cleaning** — Use a soft cloth dampened with either a commercial, nonabrasive cleaner or a solution of 70% alcohol in water, lightly wiping the surfaces of the warming unit.
- **Disinfection** — Use a soft cloth saturated with a solution of 10% chlorine bleach in tap water, lightly wiping the surfaces of the warming unit.

Performance Verification

Overview

This chapter provides performance verification procedures to be used when servicing the WarmTouch™ Model WT-5300A patient warming system.

Power Fail / Start Alarm Check

This procedure ensures the Power Fail / Start Alarm functions correctly and can be canceled properly. Perform this procedure before returning the warming system into service.

**Note:**

The Power Fail/Start Alarm is only found on WT-5300A warming units containing a PCBA with part number GR100307. WT-5300A warming units with earlier versions of the Control PCBA (referred to as the Universal PCBA in earlier versions of this manual) do not have this alarm, and do not need this test.

At power up, both audible and visual alarms activate, regardless of the reason for power loss. Selecting any blower temperature cancels both types of alarms.

No equipment is required for this check.

To check the Power Fail / Start Alarm:

1. Plug in the warming system.
2. Turn on the warming system using the power switch. The audible alarm should sound intermittently, and the warning light should be on steady. The Low temperature indicator light on the control panel should also be on steady.
3. Select any temperature setting. The audible alarm should stop, and the warning light should turn off. The indicator light for the selected temperature should be on steady.
4. Turn off the warming system and unplug it.

Thermostat Protection Check

This procedure checks to ensure that the thermostat protection controls are working properly. This procedure should be performed before returning the warming system into service.

Calibration of the thermostat protection is neither required nor possible. If the test time or temperatures are outside the allowable range, factory service is required. Contact your local Nellcor representative.

Table 4. Equipment Required for Thermostat Protection Check

Equipment	Description / Use
Temperature probe	Mon-a-Therm subcutaneous temperature probe, or equivalent, and monitor with an accuracy of $\pm 0.2^{\circ}\text{C}$.
Tape	To hold the temperature probe in place.
Stopwatch	Manual or electronic
Jumper wire with alligator clips	3 to 12 in (8 to 30 cm) long, alligator clip at each end, 12 gauge minimum.
Phillips screwdriver	#2 / Loosening and tightening test port screw.
<i>WarmTouch CareDrape</i> Lower Body blanket	To complete patient warming system.

To check thermostat protection:

1. Lay the temperature probe beside the warming unit nozzle at the end of the hose and bend approximately 1.5 inches (4 cm) of the temperature probe into the nozzle opening.
2. Position the tip of the temperature probe approximately 1 to 2 in (2.5 to 5 cm) inside the nozzle, centered in the nozzle opening.
3. Tape the probe in place.
4. Connect the probe to the temperature monitor.
5. Connect the nozzle to the blanket.
6. Unplug the warming system.
7. Loosen the over-temperature test port screw. See Figure 8.
8. Slide the over-temperature test port cover to the side.

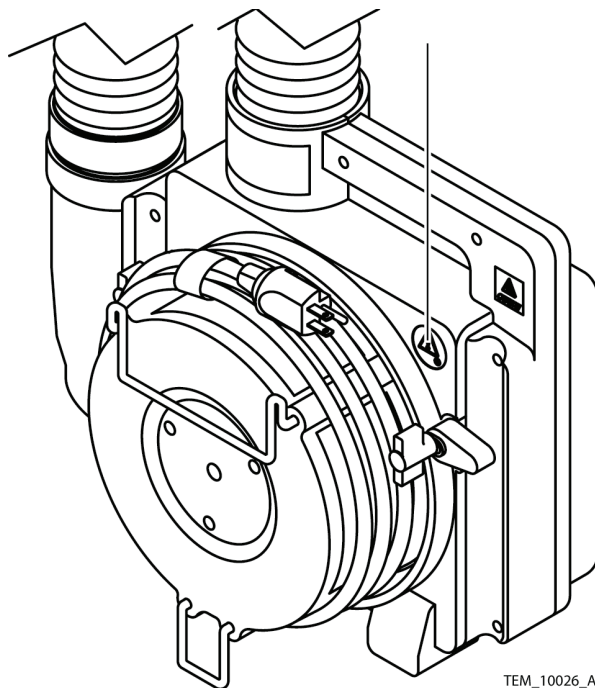

Figure 8. Over-Temperature Test Port



WARNING

Possible patient injury. Connecting the jumper wire disables (shorts out) the thermistor that is part of the temperature control system.

9. Connect the jumper wire across the two terminals in the over-temperature test port.
10. Plug in the warming system and turn it on.
11. Select the Boost temperature setting. See Figure 9.

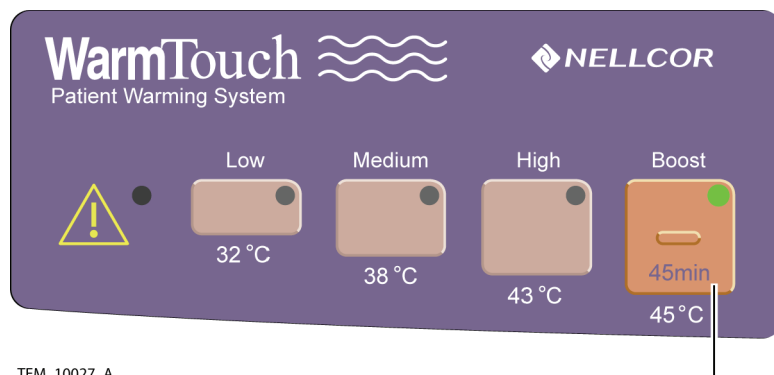

Figure 9. WT-5300A Boost Temperature Setting

12. When the monitored temperature exceeds 46°C, start the stopwatch.
13. When the alarm starts to sound and the warning light indicator lights, stop the stopwatch. See Figure 10.

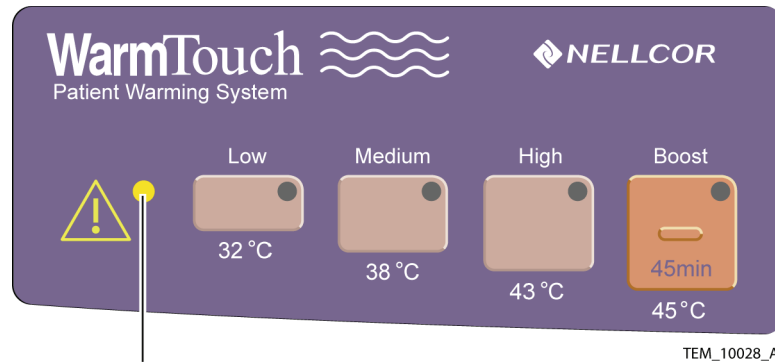

Figure 10. Warning Light

14. Time elapsed on the stopwatch should be 5 minutes or less, and the temperature monitor should not exceed 58°C.
15. Turn off the warming system and unplug it.



WARNING

Possible patient injury. Connection of the jumper wire disables (shorts out) the thermistor that is part of the temperature control system. The jumper wire must be removed.

16. Remove the jumper wire from the over-temperature test port. See Figure 8.
17. Close the over-temperature test port and tighten the screw.
18. Disconnect the warming unit from the blanket.
19. Allow the warming unit to cool for 30 minutes before using it on a patient.

Output Temperature Check

This procedure measures the warming system output air temperature at the input to the blanket. This procedure should be performed before returning the warming system into service.

Calibration of the temperature control circuit is neither required nor possible. If the test temperatures are outside the allowable range, factory service is required. Contact your local Nellcor representative.

Table 5. Equipment Required for Output Temperature Check

Equipment	Description/Use
Temperature Probe	Mon-a-Therm subcutaneous temperature probe, or equivalent, and monitor with an accuracy of $\pm 0.2^{\circ}\text{C}$.
Tape	To hold the temperature probe in place.
<i>WarmTouch CareDrape™</i> Lower Body blanket	To complete patient warming system.

To check output temperature:

1. Lay the temperature probe alongside the warming unit nozzle at the end of the hose and bend approximately 1.5 in (4 cm) of the temperature probe into the nozzle opening.
2. Position the tip of the temperature probe so that it is approximately 1 to 2 in (2.5 to 5cm) inside the nozzle, centered in the nozzle opening.
3. Tape the probe in place.
4. Connect the probe to the temperature monitor.
5. Connect the nozzle to the blanket.
6. Extend the hose to match the configuration shown in Figure 11.

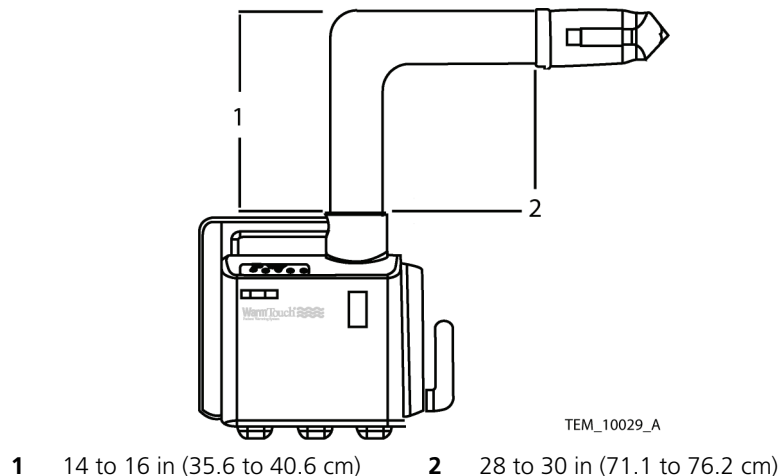

Figure 11. Output Temperature Test Setup

7. Turn on the warming system.
8. Select the Low temperature setting (Figure 12, item 1).

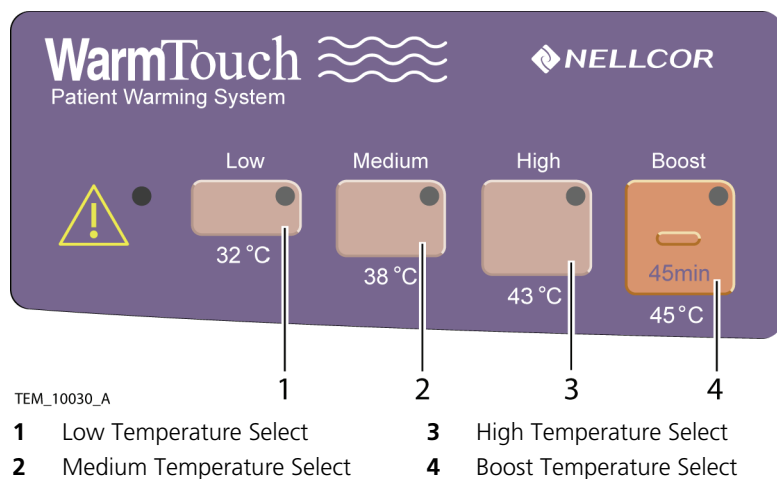

Figure 12. Temperature Selection

9. Allow 8 to 10 minutes for the temperature to stabilize at the Low setting. The temperature monitor should indicate 30°C to 34°C.
10. Select the Medium temperature setting (Figure 12, item 2).
11. Allow 8 to 10 minutes for the temperature to stabilize at the Medium setting. The temperature monitor should indicate 36°C to 40°C.
12. Select the High temperature setting (Figure 12, item 3).

13. Allow 8 to 10 minutes for the temperature to stabilize at the High setting. The temperature monitor should indicate 41°C to 45°C.
14. Select the Boost temperature setting (Figure 12, item 4).
15. Allow 8 to 10 minutes for the temperature to stabilize at the High setting. The temperature monitor should indicate 44°C to 46°C.
16. Turn off the warming system and unplug it.
17. Disconnect the warming unit from the blanket.
18. Remove the temperature probe from the nozzle.
19. Allow the warming system to cool for 30 minutes before using it on a patient.

Safety Tests

The warming system is provided with a ground stud to allow safety testing without opening the case. See Figure 13.



TEM_10088_A

Figure 13. Ground Stud



Note:

Use applicable standards for institution and country. Test equipment and its application must comply with the applicable standard.

To perform safety tests:

- Test ground integrity. See page 99 for test values.
- Test earth leakage current. See page 100 for test values.
- Test enclosure leakage current. See page 100 for test values.

Repair

Overview

This chapter provides procedures for servicing the WarmTouch™ Model WT-5300A patient warming system.

**WARNING**

Before attempting to open or disassemble the warming system, disconnect the power cord from the AC power source.

**Caution**

Observe ESD (electrostatic discharge) precautions when working within the warming system.

**Caution**

Repairs to the warming system should only be accomplished by trained service technicians.

Follow local government ordinances and recycling instructions regarding the disposal of the warming system and/or parts.

Filter Cover Assembly Replacement

Table 6. Filter Cover Assembly Components

Qty	Component
1	Filter cover
1	Bed hook
1	Foot, filter cover, short
4	Truss HD screws (8-32)
1	Gasket, WarmTouch
1	Label, operating instructions
1	Label, grounding reliability
1	Label, danger, anesthetics

Table 7. Tools Required for Replacing Filter Cover Assembly

Tool	Parameter / Use
Phillips screwdriver	#2 / Removing screws.
Torque driver	8 to 12 in/lbs (20 to 30 cm/kg)
Allen wrench	3/32" / Loosening retaining bracket screws.
Flat blade screwdriver	Detaching filter cover from power cord.

To replace the filter cover assembly:

1. Unplug the warming system power cord from the AC outlet.
2. Lay the warming unit on its front side, so the bottom of the unit is visible.

- Unwind the power cord from the filter cover. See Figure 14.

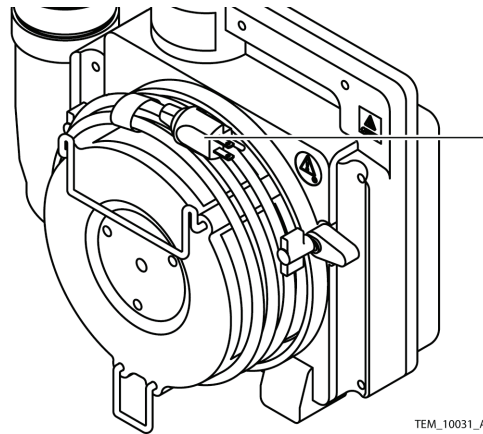
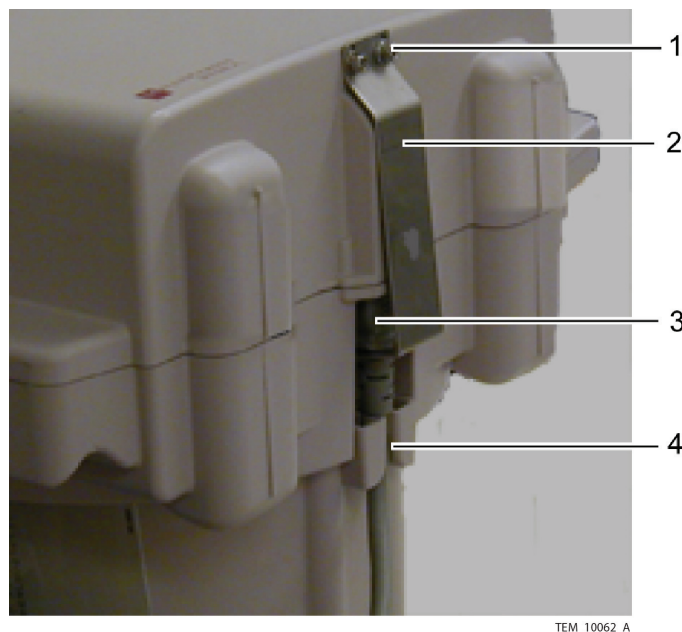

Figure 14. Power Cord

- Loosen the retaining bracket screws slightly, so that the retaining bracket can be pulled away from the power cord connector. See Figure 15.



- | | | | |
|---|--------------------------|---|----------------------------|
| 1 | Retaining Bracket Screws | 3 | Power Cord Connector |
| 2 | Retaining Bracket | 4 | Power Cord Routing Bracket |

Figure 15. Power Cord Routing

- Unseat the power cord from the power cord routing bracket (Figure 15, item 4) on the filter cover. If necessary, use the head of the flat blade screwdriver to separate the halves of the bracket sufficiently to allow unseating of the cord.

- Remove the filter cover screws. See Figure 16.

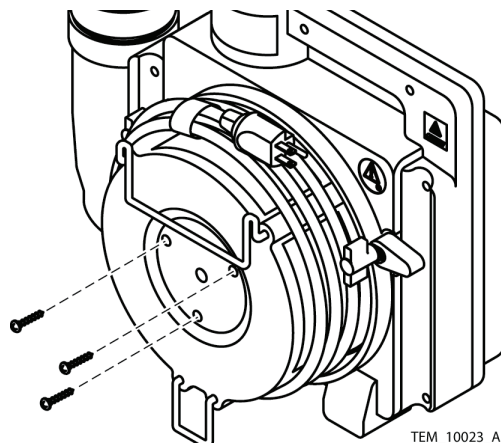

Figure 16. Filter Cover Screws

- Remove the filter cover assembly from the warming unit.
- Place the replacement filter cover assembly on the warming unit and install the screws. Tighten the screws to 8 to 12 in/lbs (20 to 30 cm/kg). See Figure 16.
- Slide the power cord retainer bracket over the power cord connector and tighten the retainer bracket screws until snug.
- Reseat the power cord into the power cord routing bracket. If necessary, use the head of the flat blade screwdriver to separate the halves of the bracket sufficiently to allow reseating of the cord.

Separating the Front and Rear Covers

Table 8. Tools Required for Separating Front and Rear Covers

Tool	Parameter / Use
Phillips screwdriver	#2 / Removing screws.
Allen wrench	3/32" / Loosening retaining bracket screws.
Flat blade screwdriver	Detaching power cord from filter cover.

To separate the warming unit covers:

- Unplug the warming system power cord from the AC outlet.
- Lay the warming unit on its front side, so that the bottom of the unit is visible.

- Unwind the power cord from the filter cover. See Figure 17.

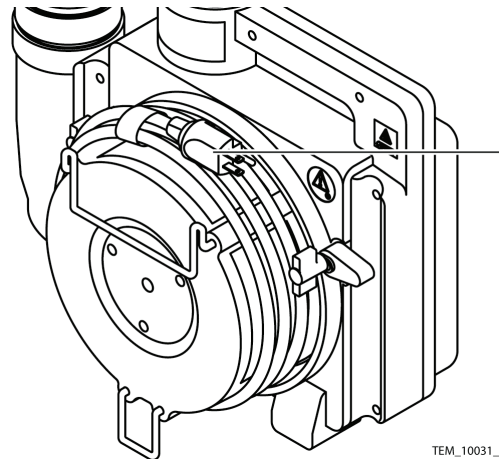
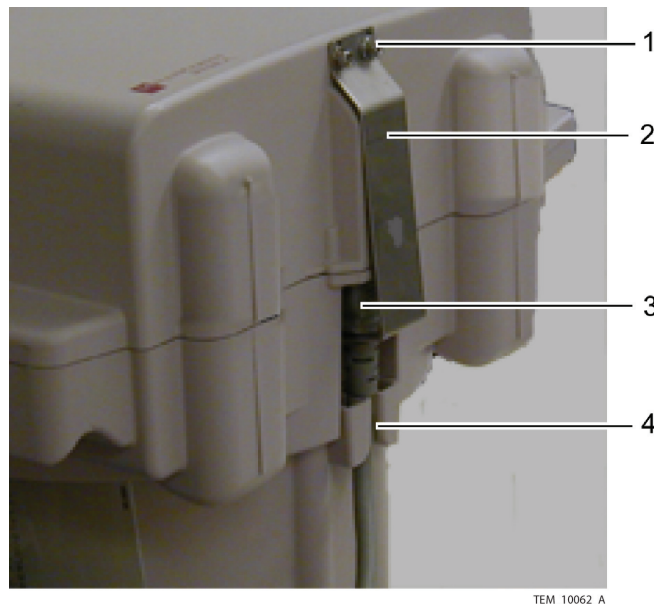

Figure 17. Power Cord

- Loosen the retaining bracket screws slightly, so that the retaining bracket can be pulled away from the power cord connector. See Figure 18.



- | | |
|-----------------------------------|-------------------------------------|
| 1 Retaining Bracket Screws | 3 Power Cord Connector |
| 2 Retaining Bracket | 4 Power Cord Routing Bracket |

Figure 18. Power Cord Routing

- Unseat the power cord from the power cord routing bracket (Figure 18, item 4) on the filter cover. If necessary, use the head of the flat blade screwdriver to separate the halves of the bracket sufficiently to allow unseating of the cord.

6. Disconnect the power cord connector (Figure 18, item 3) from its socket in the blower housing.
7. Remove the screws holding the front and rear covers together. See Figure 19.

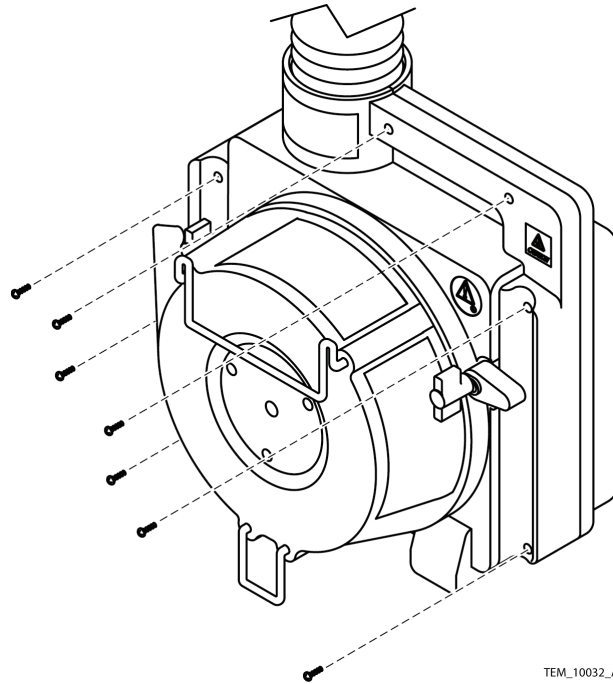

Figure 19. Cover Screw Locations



Caution

Separate the front and rear covers **very carefully**. Do not apply too much pressure to the wires connecting the covers. They are short and easily damaged.

8. Carefully separate the front and rear covers. See Figure 20.

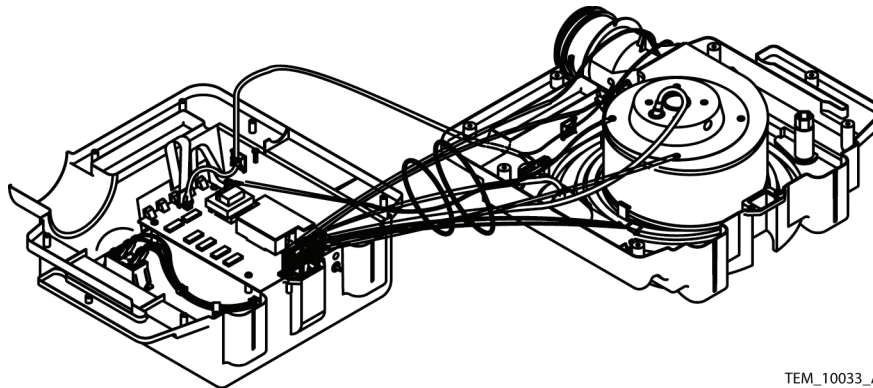

Figure 20. Separated Covers

Rejoining the Front and Rear Covers



Caution

Ensure that the cable harness between the two covers is not pinched by the covers when joining them back together.

To rejoin the warming unit covers:

1. Carefully align the covers and put them back together, placing the rear cover atop the front cover so that the covers nest.
2. Install the screws through the holes in the rear cover to attach it to the front cover. Tighten screws to 7 to 10 in/lbs (18 to 25 cm/kg). See Figure 21.

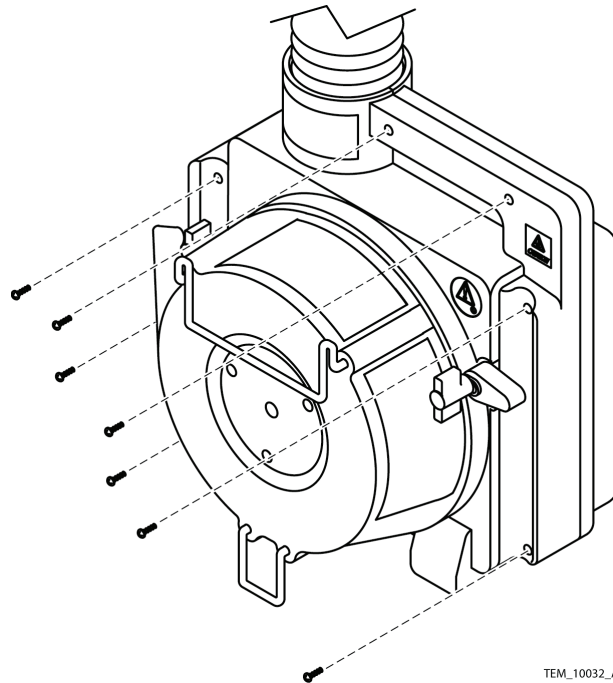

Figure 21. Cover Screw Locations

3. Connect the power cord connector to the warming unit, making sure the connector is fully inserted into the socket in the warming unit housing.
4. Slide the power cord retainer bracket over the power cord connector and tighten the retainer bracket screws until snug.
5. Reseat the power cord into the power cord routing bracket on the filter cover. If necessary, use the head of the flat blade screwdriver to separate the halves of the bracket sufficiently to allow reseating of the cord.

Front Cover Assembly Replacement

Table 9. Filter Cover Assembly Components

Qty	Component
1	Front enclosure
1	Key pad
1	Lens
1	Ground symbol label
1	Cable tie mount
1	Cable clamp
1	Ground equipotential label
1	0.25 in (6.5 mm) hole for equipotential ground pin

Table 10. Tools Required for Replacing Front Cover Assembly

Tool	Parameters / Uses
Phillips screwdriver	#2
Torque driver/wrench	4 to 12 in/lbs (10 to 30 cm/kg)
	36 to 40 in/lbs (91 to 112 cm/kg)
Wire cutter	Cutting cable ties.
Socket wrench	10 mm
Flat blade screwdriver	Detaching power cord from filter cover.
Contact removal tool	Souriau RX2025GE1 or equivalent



Note:

The unit under service may have a Control PCBA that appears slightly different from the Control PCBA shown in this manual. However, procedural steps involving the Control PCBA are not changed.

To replace the front cover assembly:

1. Separate the front and rear covers. See page 38, *Separating the Front and Rear Covers*.

- Cut the cable harness bundle ties. See Figure 22.

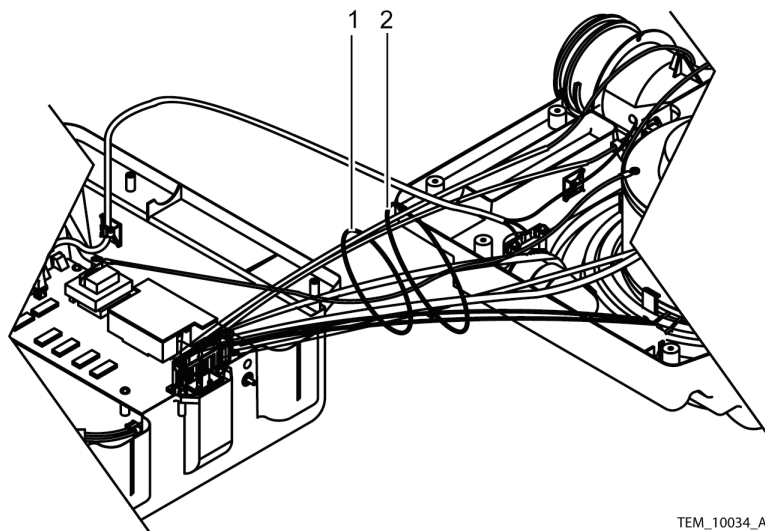
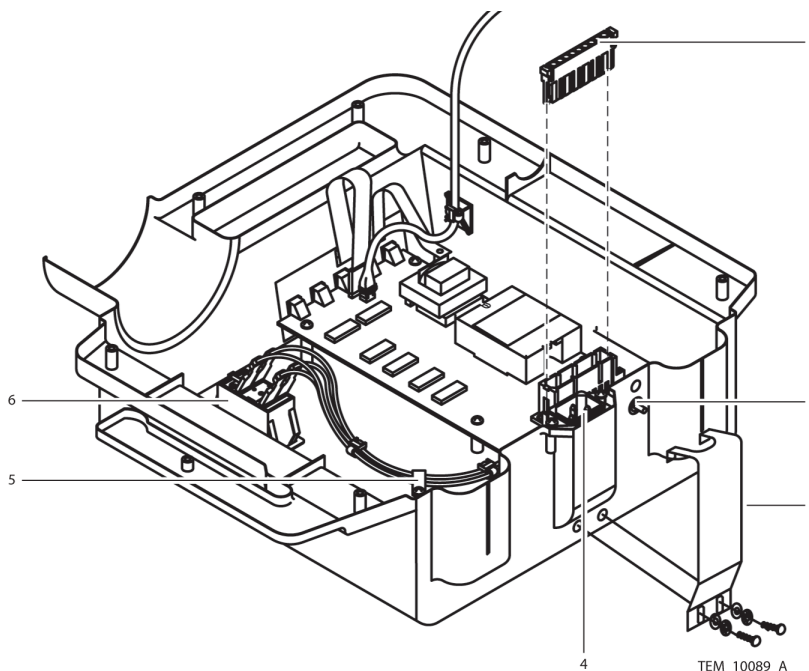

Figure 22. Cable Harness Bundle Ties

- Disconnect the 9-pin connector from the Control PCB (Figure 23, item 1).



- | | | | |
|---|-------------------------------|---|--------------------|
| 1 | 9-Pin Connector | 4 | AC Power Connector |
| 2 | Equipotential Ground Terminal | 5 | Cable Clamp |
| 3 | Power Cord Retaining Bracket | 6 | Power Switch |

Figure 23. Front Cover Assembly

4. Disconnect the equipotential ground stud and remove it from the front cover assembly (Figure 23, item 2).
5. Remove the AC power connector from the front cover assembly (Figure 23, item 4).
6. Remove the cable clamp from the front cover assembly (Figure 23, item 5).
7. Remove the acorn nuts from the ends of the screws securing the power cord retaining bracket (Figure 23, item 3). Save the nuts for use in step 32.
8. Loosen the screws securing the retaining bracket until the nut plates are free. Remove and set aside the nut plates for use in step 32.
9. Pull out the screws to remove the retaining bracket. Save the bracket, screws, and locking washers for use in step 31.

**Caution**

Write down the color code of each wire connected to the power switch. This will ensure that the wires will be reconnected properly.

10. Disconnect the four wires from the power switch. See Figure 24.
11. Depress the four clips on the power switch and push the power switch through its hole in the front cover assembly. See Figure 24.

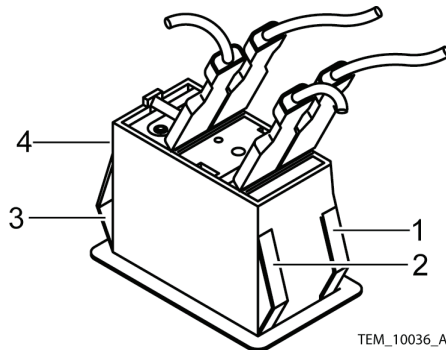

Figure 24. Power Switch Clips and Wires

12. Cut the cable tie securing the thermistor cable to the front cover assembly (Figure 25, item 1).

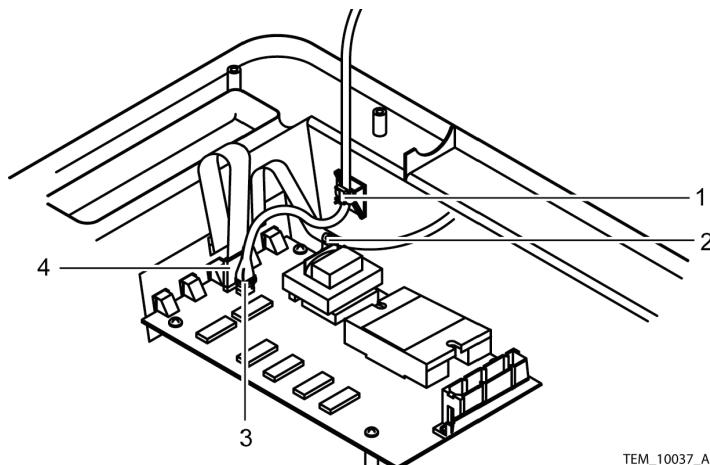

Figure 25. Cable Disconnect

13. Remove the ground screw (Figure 25, item 2).
14. Cut the cable tie securing the thermistor cable connector (Figure 25, item 3) to the Control PCBA.
15. Disconnect the thermistor cable (Figure 25, item 3).
16. Disconnect the ribbon cable (Figure 25, item 4).
17. Remove the screws holding the Control PCB onto the front cover assembly. See Figure 26.

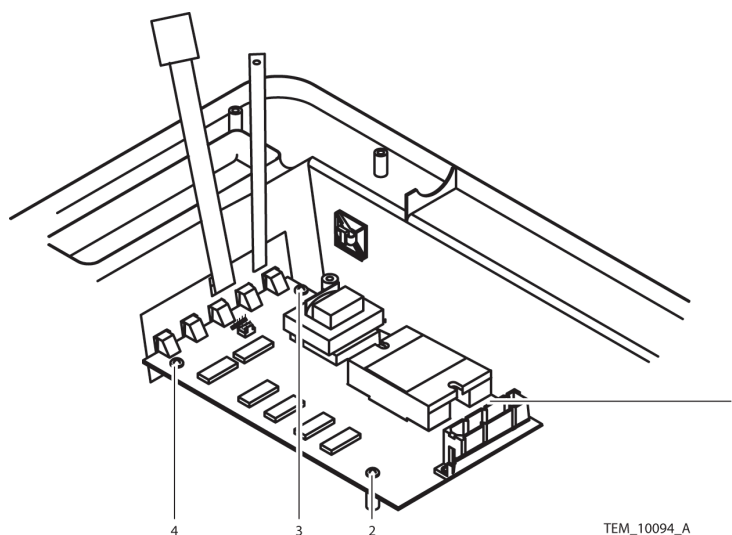

Figure 26. Control PCB Screws

18. Carefully lift the Control PCB out of the front cover assembly.
19. Discard the old front cover assembly.

**Caution**

Carefully align the lights on the Control PCB with the control panel key pad push buttons. Failure to do so could damage the key pad or the Control PCB lights. See Figure 27, items 1-5.

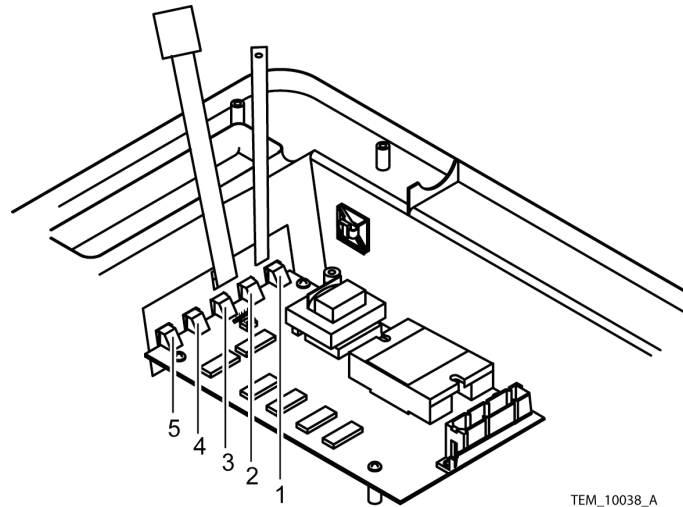

Figure 27. Control PCB Lights

20. Carefully place the Control PCB into the replacement front cover assembly and install the mounting screws. Tighten the screws to 4 to 6 in/lbs (10 to 15 cm/kg). See Figure 28.

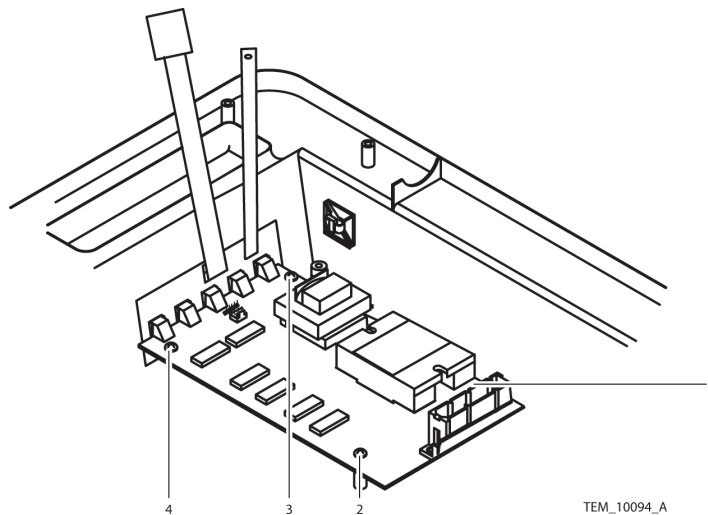

Figure 28. Control PCB Screws

21. Connect the ribbon cable (Figure 29, item 4) to the Control PCBA.

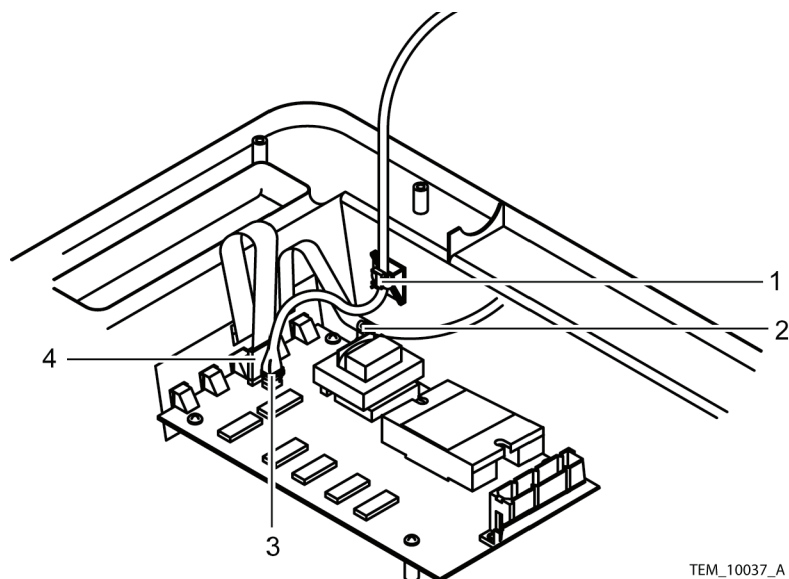

Figure 29. Cable Connections

TEM_10037_A

22. Connect the thermistor cable (Figure 29, item 3).
23. Install a cable tie around the thermistor cable connector (Figure 29, item 3) and Control PCB connector to secure the thermistor cable to the PCBA.
24. Connect the keypad grounding strap and blower ground wire. See Figure 29, item 2. Tighten the screw to 4 to 6 in/lbs (10 to 15 cm/kg).
25. Install a cable tie around the thermistor cable and the cable tie mount (Figure 29, item 1) to secure the thermistor cable to the front cover.
26. Slide the power switch through its hole in the front of the front cover assembly until the four clips on the power switch click into place. Ensure that the "0", marked on the front of the power switch, is towards the bottom of the front cover assembly. See Figure 30.

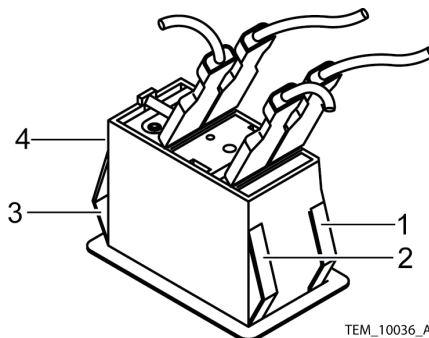

Figure 30. Power Switch Clips and Wires

TEM_10036_A

27. Connect the four wires to the power switch. Make sure to reconnect the wires in the same way they were connected before; refer to the list of wire colors and where they were connected to the switch, as recorded in Step 10. See Figure 31, item 6.

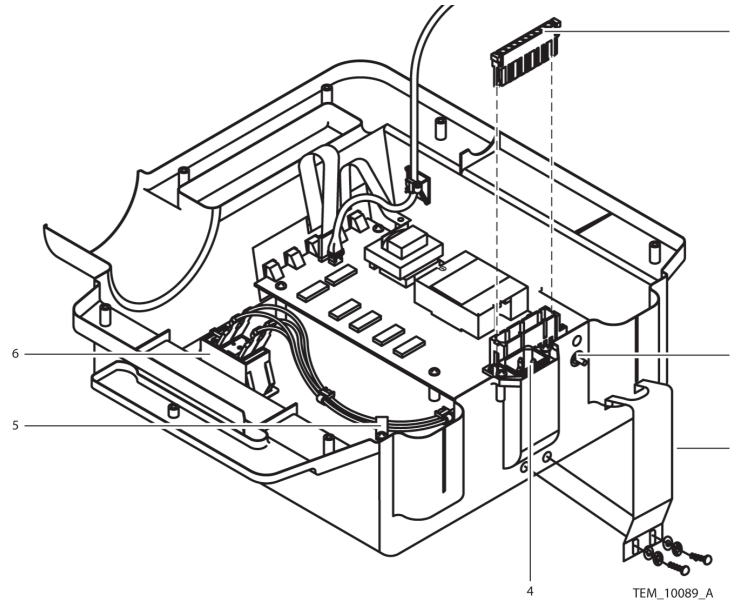
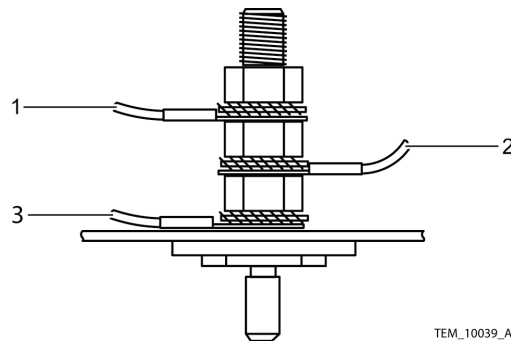

Figure 31. Front Cover Assembly Component Locations

28. Install the cable clamp around the power switch cables. Tighten the screw to 4 to 6 in/lbs (10 to 15 cm/kg). See Figure 31, item 5.
29. Install the AC power connector into the front cover assembly. Tighten screws to 4 to 6 in/lbs (10 to 15 cm/kg). See Figure 31, item 4.
30. Install the equipotential ground (Figure 31, item 2) and attach ground wires as shown in Figure 32. Tighten nuts to 36 to 44 in/lbs (91 to 112 cm/kg).



- 1** Blower Housing Ground **3** AC Power Connector Ground
2 Blower Motor Ground

Figure 32. Equipotential Ground Stud Wiring

31. Insert the screws for the retaining bracket (saved in step 9) through the locking washers, then through the holes in the retaining bracket and into the holes in the front cover (see Figure 31, item 3).
32. On the inside of the front cover, screw the retaining bracket screws through the nut plates (saved in step 8), then finish securing the bracket by fastening the acorn nuts (saved in step 7) onto the ends of the screws.
33. Connect the 9-pin connector to the Control PCB. See Figure 31, item 1.
34. Install the cable harness bundle ties. See Figure 33.

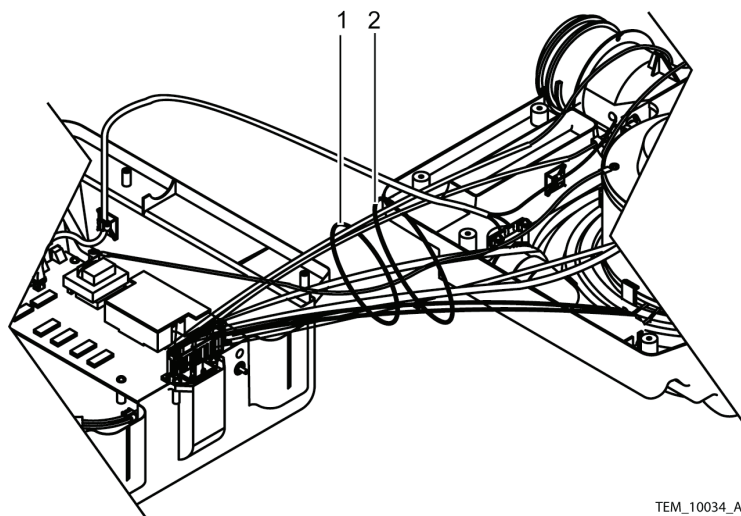

Figure 33. Cable Harness Bundle Ties

35. Rejoin the front and rear covers. See page 41, *Rejoining the Front and Rear Covers*.
36. Perform the following checks/tests to verify proper operation of the warming unit prior to returning it into service:
 - a. *Power Fail / Start Alarm Check* on page 27
 - b. *Thermostat Protection Check* on page 28
 - c. *Output Temperature Check* on page 31
 - d. *Safety Tests* on page 33

Control PCBA Replacement

The replacement Control PCB (P/N GR100307) comes fully assembled except for the solid state relay assembly.

Table 11. Tools Required for Replacing Control PCB

Tool	Parameter / Use
Phillips screwdriver	#2 / Removing screws.
Torque driver	4 to 20 in/lbs (10 to 51 cm/kg)
Wire cutter	Cutting cable ties and jumpers.
Allen wrench	3/32" / Adjusting retaining bracket screws.
Flat blade screwdriver	Detaching power cord from filter cover.

To replace the Control PCB assembly:

1. Separate the front and rear covers. See page 38, *Separating the Front and Rear Covers*.
2. Disconnect the 9-pin connector from the Control PCB (Figure 34, item 1).

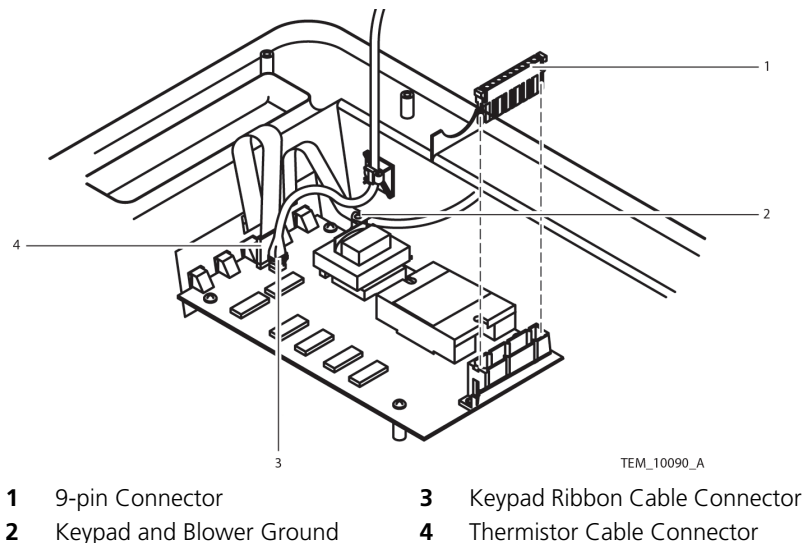

Figure 34. Control PCB Connections

3. Cut the cable tie securing the thermistor cable connector (Figure 34, item 4) to the Control PCBA.
4. Disconnect the thermistor cable.
5. Disconnect the ribbon cable (Figure 34, item 3).

6. Remove the screws holding the Control PCB onto the front cover assembly.

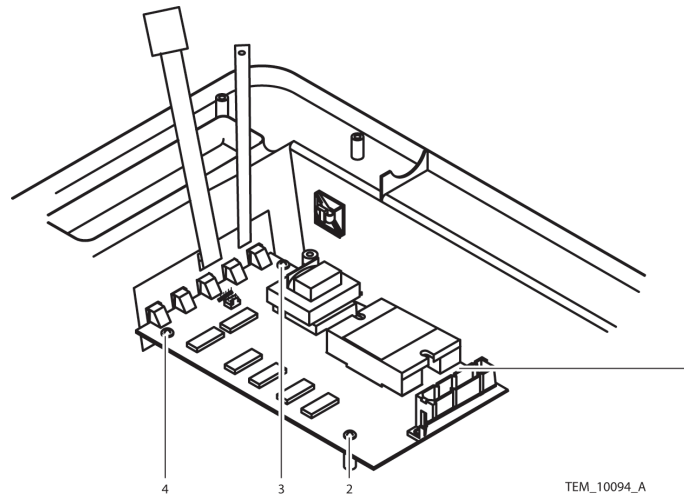

Figure 35. Control PCB Screws

7. Carefully lift the Control PCB out of the front cover assembly.
8. Remove the solid state relay from the Control PCB. See Figure 36.

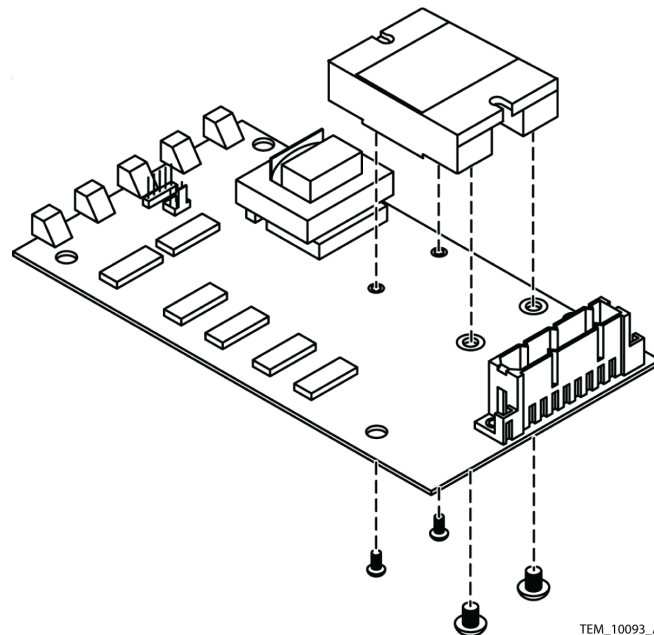

Figure 36. Control PCB Relay Assembly Removal

9. Install the solid state relay onto the replacement Control PCB. Tighten the smaller screws to 7 to 10 in/lbs (18 to 25 cm/kg). Tighten the larger screws to 17 to 20 in/lbs (43 to 51 cm/kg). See Figure 36.

**Caution**

Carefully align the lights on the Control PCB with the control panel key pad push buttons. Failure to do so could damage the key pad or the Control PCB lights. See Figure 37, items 1-5.

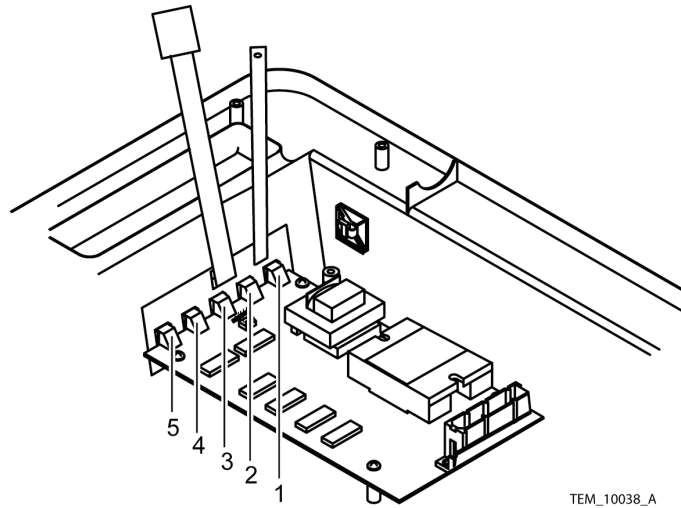

Figure 37. Control PCB Lights

10. Carefully place the replacement Control PCB into the front cover assembly and install the mounting screws. Tighten the screws to 4 to 6 in/lbs (10 to 15 cm/kg). See Figure 38.

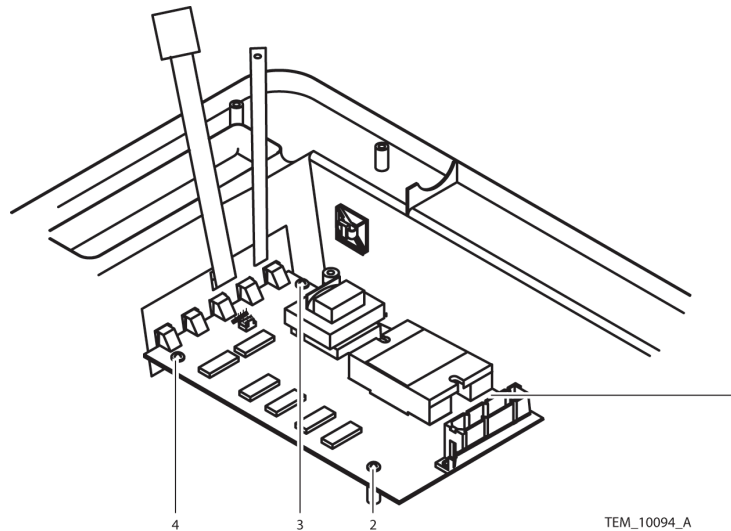

Figure 38. Control PCB Screws

11. Connect the ribbon cable (Figure 39, item 3).

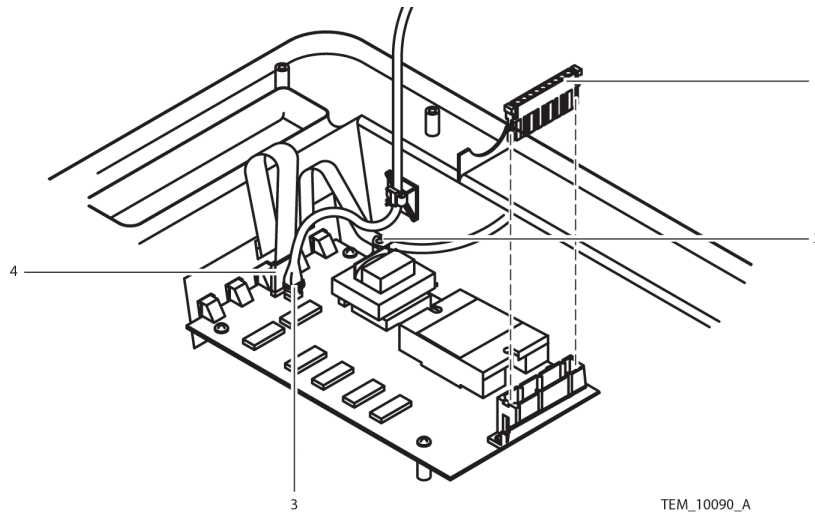

Figure 39. Cable Connections

12. Connect the thermistor cable.

13. Install a cable tie around the thermistor cable connector (Figure 39, item 4) and Control PCB connector to secure the thermistor cable to the PCBA.

14. Connect the 9-pin connector to the Control PCB (Figure 39, item 1).

15. Install the cable harness bundle ties. See Figure 40, item 1.

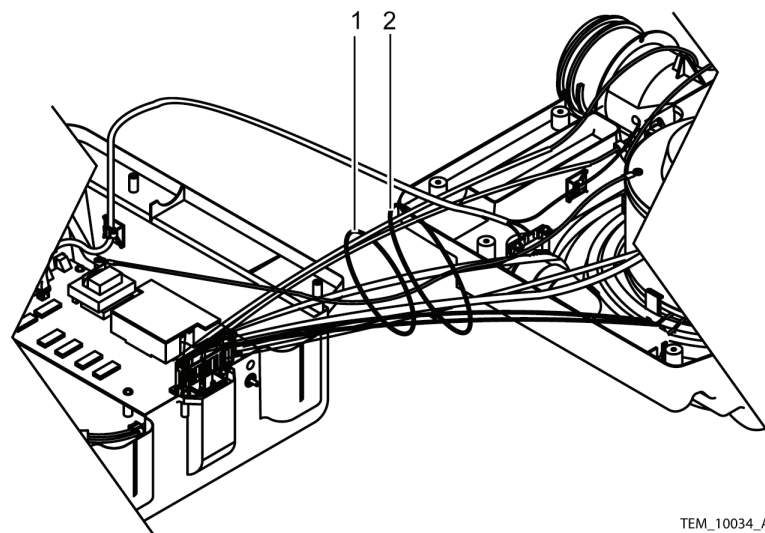

Figure 40. Cable Harness Bundle Ties

16. Rejoin the front and rear covers. See page 41, *Rejoining the Front and Rear Covers*.
17. Perform the following checks/tests to verify proper operation of the warming unit prior to returning it into service:
 - a. *Power Fail / Start Alarm Check* on page 27
 - b. *Thermostat Protection Check* on page 28
 - c. *Output Temperature Check* on page 31
 - d. *Safety Tests* on page 33

Heater Assembly Replacement

Table 12. Heater Assembly Components

Qty	Component
1	Heater, 230V
2	Pins, 16-18 GA, 13 A

Table 13. Tools Required for Replacing Heater Assembly

Tool	Parameter / Use
Phillips screwdriver	#2 / Removing screws
Wire cutter	Cutting cable ties
Socket	10 mm
Contact removal tool	Souriau RX2025GE1 or equivalent
Torque driver/wrench	4 to 12 in/lbs (10 to 30 cm/kg)
	36 to 44 in/lbs (91 to 112 cm/kg)
Flat blade screwdriver	Detaching power cord from filter cover

To replace the heater assembly:

1. Remove the filter cover assembly from the rear cover assembly. See page 36, *Filter Cover Assembly Replacement*.

2. Remove the filter from the rear cover assembly. See Figure 41, item 1.



Figure 41. Filter Removal



Note:

The blower assembly is attached to the rear cover assembly by four screws and four clips. It is easier for two people to release the clips and lift the blower assembly from the rear cover assembly.

3. Remove the screws holding the blower assembly to the rear cover assembly. See Figure 42.

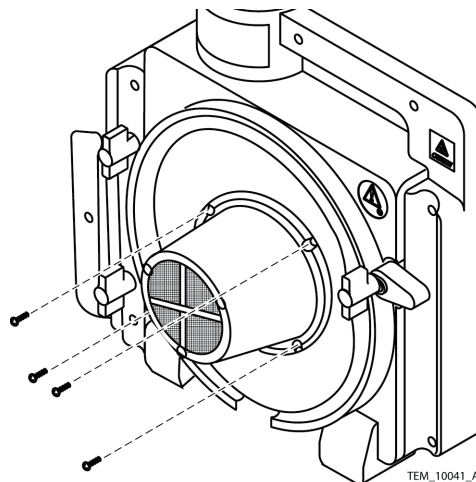

Figure 42. Blower Assembly Screws

4. Separate the front and rear covers. See page 38, *Separating the Front and Rear Covers*.

- Cut the cable harness bundle ties. See Figure 43, items 1 and 2.

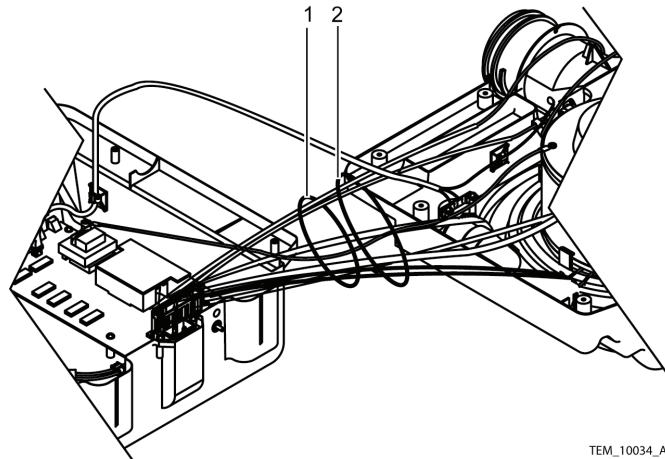

Figure 43. Cable Harness Bundle Ties

- Disconnect the 9-pin connector from the Control PCB. See Figure 44, item 1.



Note:

During the remainder of this procedure, make sure not to apply excessive pressure to the wires still connected between the separated halves of the warming unit.

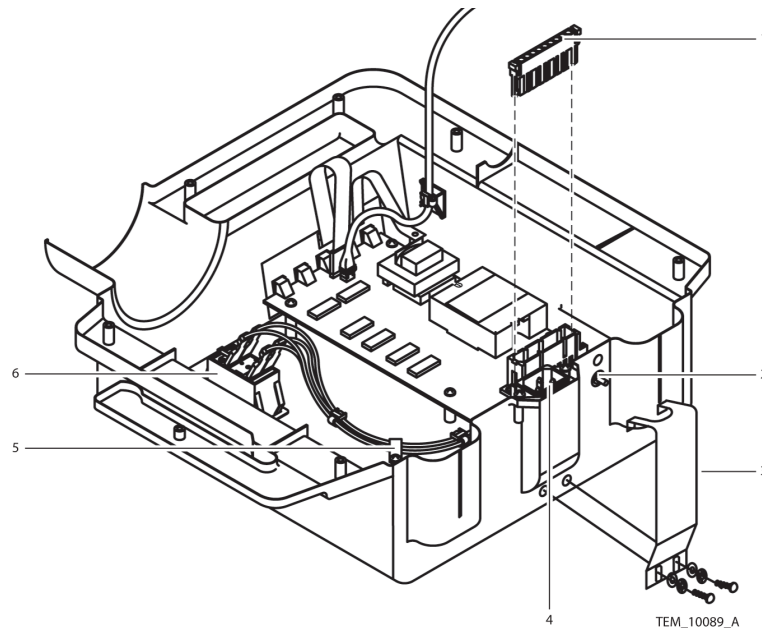

- | | | | |
|---|-------------------------------|---|--------------------|
| 1 | 9-Pin Connector | 4 | AC Power Connector |
| 2 | Equipotential Ground Terminal | 5 | Cable Clamp |
| 3 | Power Cord Retaining Bracket | 6 | Power Switch |

Figure 44. Front Cover Assembly

**Caution**

Care must be taken when moving the duct adapter. The thermistor connection to the duct adapter is fragile and will become disconnected if too much pressure is applied to it.

7. Carefully lift the duct adapter and lay the duct adapter on the rear cover handle. See Figure 45.

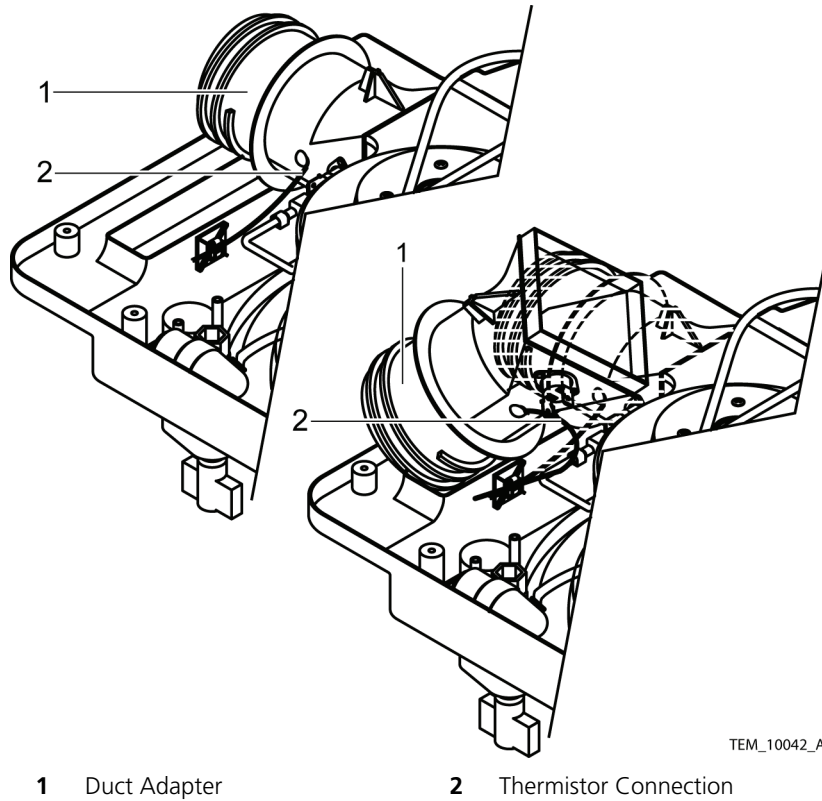

Figure 45. Duct Adapter Placement

8. Rotate the blower motor assembly clockwise to disengage two of the four clips. See Figure 46 and Figure 47.

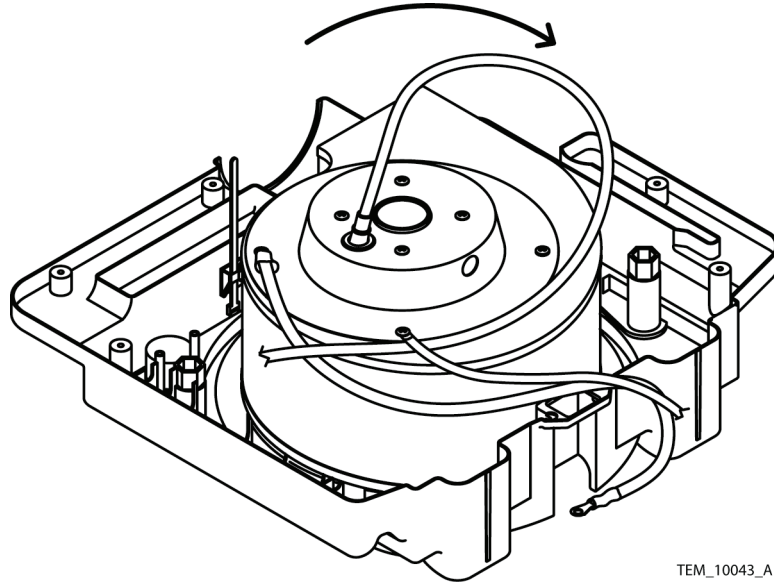

Figure 46. Blower Motor Removal

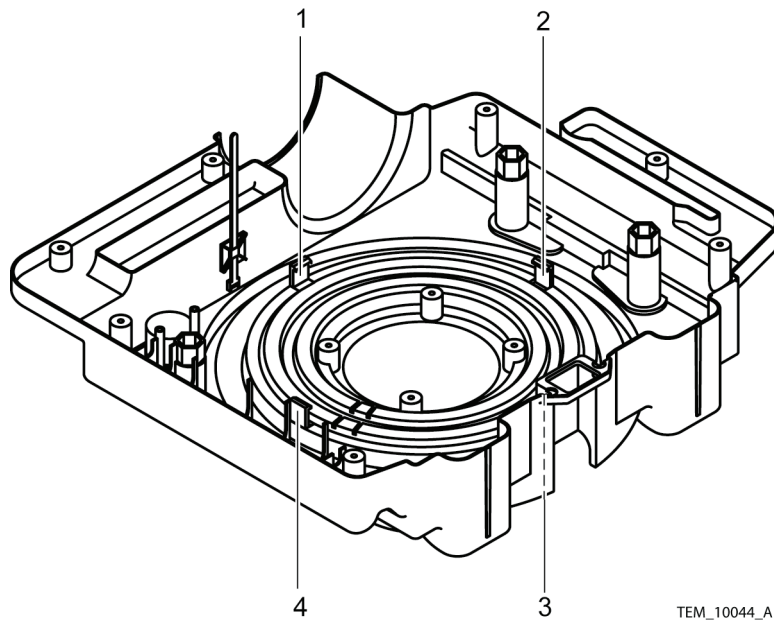
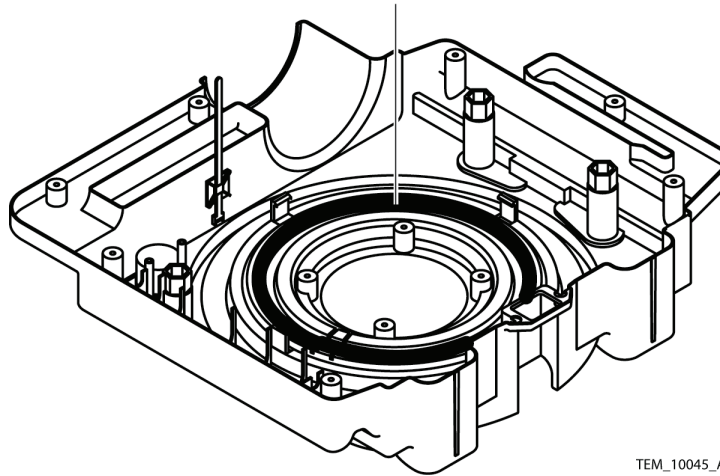

Figure 47. Blower Assembly Clips

9. Slide the blower motor assembly away from the engaged clips to disengage them.

10. Lay the blower motor assembly beside the rear cover assembly. Do not overstress the connecting wires.
11. Remove the rubber gasket from the rear cover assembly.



TEM_10045_A

Figure 48. Rubber Gasket**Caution**

Do not touch the heater coil. Body oil can damage the heater coil when it is in use.

12. Lift the heater assembly (Figure 49, item 1) out of the rear cover assembly.

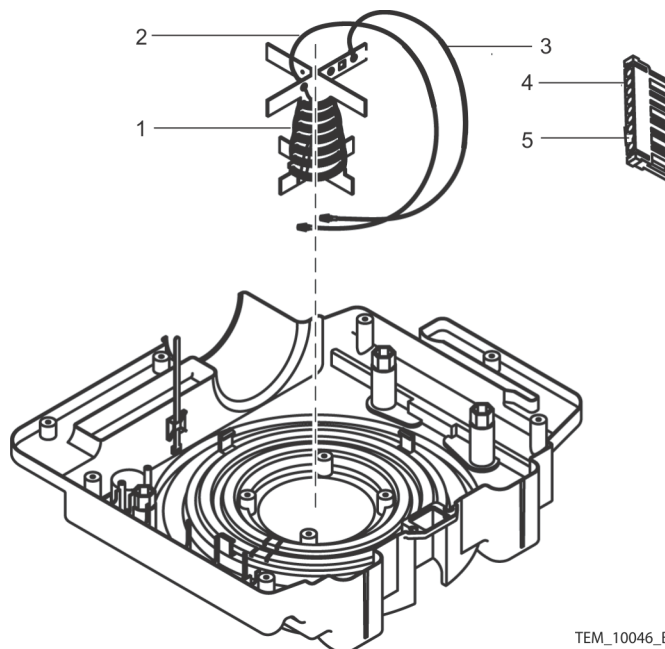

TEM_10046_B

Figure 49. Heater Assembly

**Note:**

For the next four steps, use a Souriau RX2025GE1 contact removal tool or equivalent.

13. Remove the black wire and pin (Figure 49, item 3) from pin 2 of the 9-pin connector (Figure 49, item 5).
14. Remove the red wire (may be white in some assemblies) and pin (Figure 49, item 2) from pin 8 of the 9-pin connector (Figure 49, item 4).
15. Install the red (or white) wire and pin from the new heater into pin 8 of the 9-pin connector.
16. Install the black wire and pin from the new heater into pin 2 of the 9-pin connector.

**Note:**

Ensure that the heater thermostat (Figure 50, item 3) is oriented upward when reinstalling the heater in the rear cover assembly.

17. Slide the new heater into the rear cover assembly. See Figure 50.

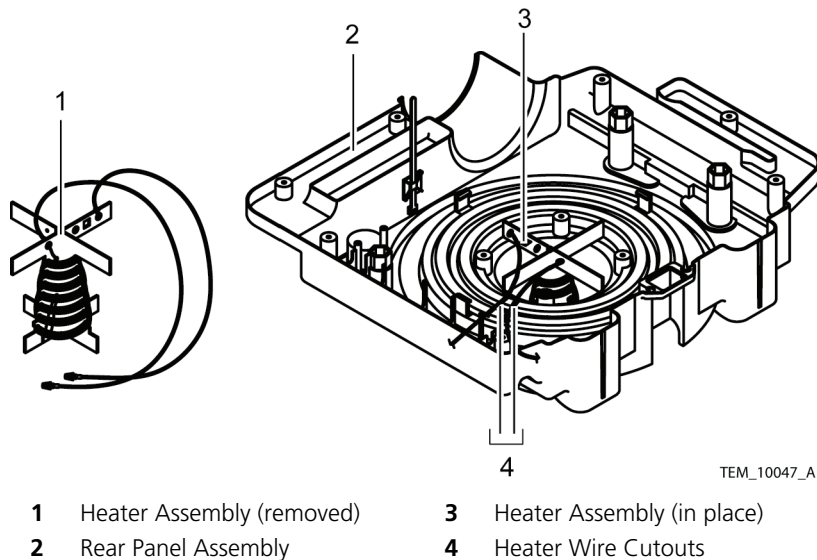
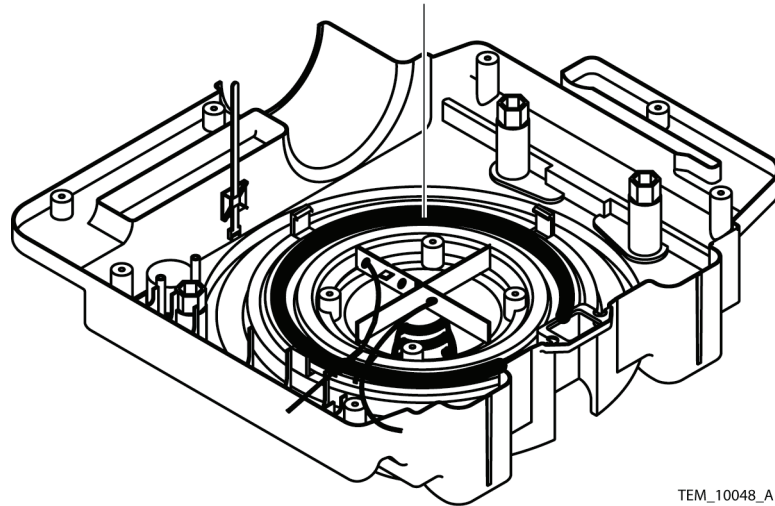

Figure 50. Heater Assembly Installation

18. Orient the heater so that the heater thermostat (Figure 50, item 3) is nearest the rear cover assembly handle (Figure 50, item 2).
19. Route the wires from the heater through the cut-outs in the rear cover assembly (Figure 50, item 4).

20. Place the rubber gasket into the rear cover assembly, with the wire indentations over the heater wires. See Figure 51, item 1.



TEM_10048_A

Figure 51. Rubber Gasket

21. Place the blower assembly into the rear cover assembly and ensure that the blower assembly clips (shown in Figure 52) attach over the edges of the blower assembly.

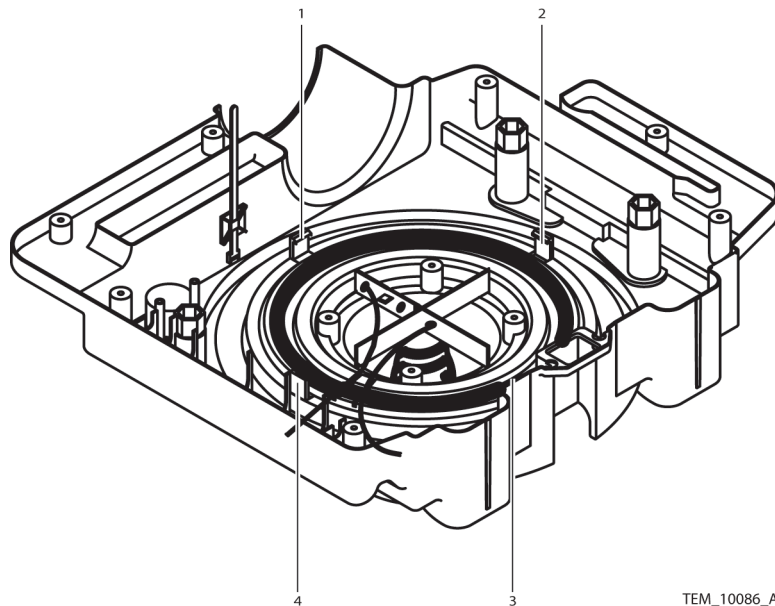

TEM_10086_A

Figure 52. Blower Assembly Clips

**Caution**

Exercise caution when moving the duct adapter. Do not apply excessive pressure, as the thermistor connection to the duct adaptor is fragile and can easily become disconnected.

22. Carefully reinsert the duct adapter into the blower assembly. See Figure 53.

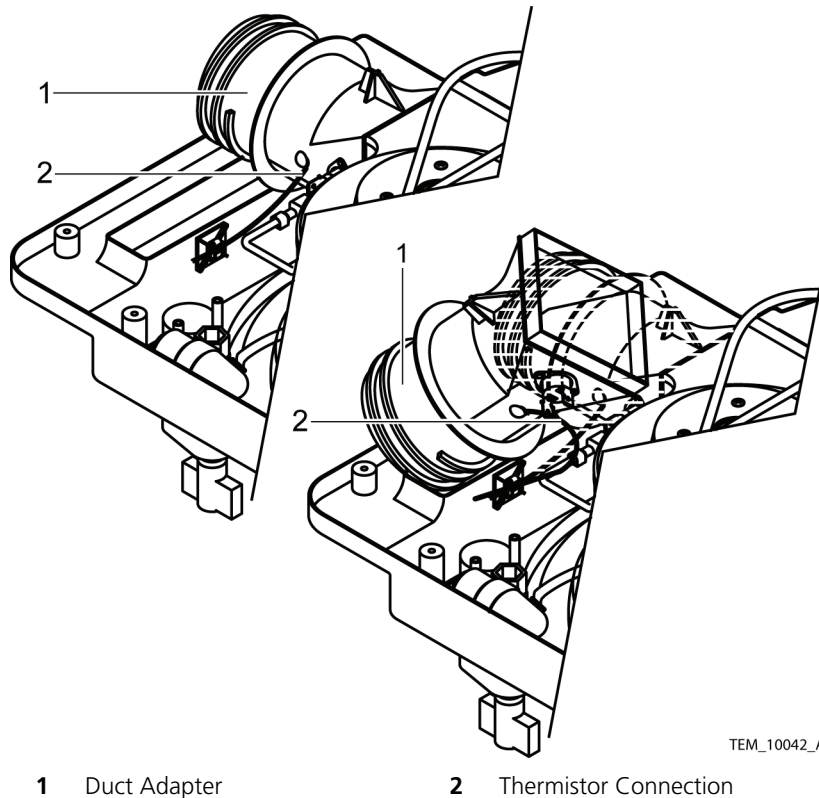

Figure 53. Duct Adapter Placement

**Note:**

If the rivet holding the thermistor in place in the duct is loose or pulled out entirely, follow the instructions in the Duct Adapter Assembly Replacement section (page 67) to reseal the thermistor.

23. Install the blower assembly mounting screws into the rear cover assembly. Tighten the screws to 4 to 6 in/lbs (10 to 15 cm/kg).

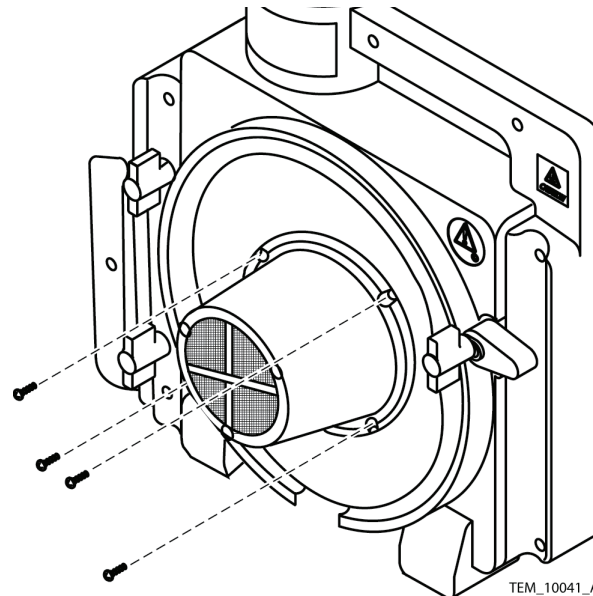

Figure 54. Blower Assembly Screws

24. Connect the 9-pin connector to the Control PCB. See Figure 44, item 1.
25. Install the cable harness bundle ties. See Figure 55, items 1 and 2.

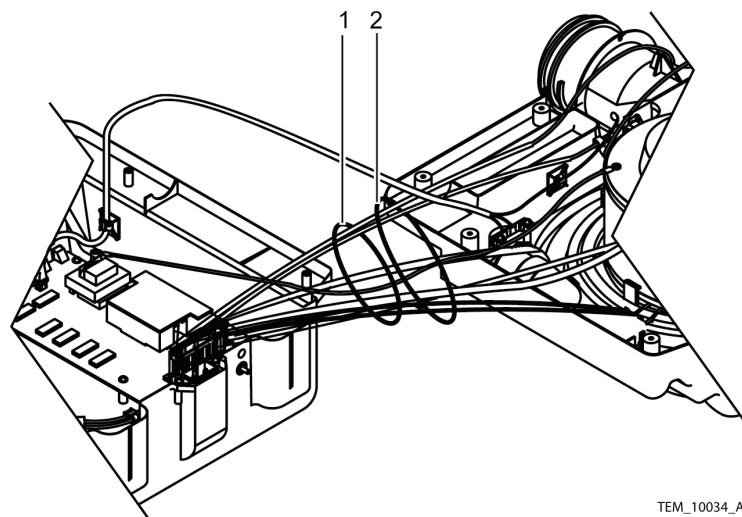

Figure 55. Cable Harness Bundle Ties

26. Rejoin the front and rear covers. See page 41, *Rejoining the Front and Rear Covers*, steps 1 and 2. However, do not reattach the power cord until after reattaching the filter cover (step 28).

27. Place the filter into the rear cover assembly.



Figure 56. Filter Installation

28. Install the filter cover assembly on the rear cover assembly. Tighten the screws to 8 to 12 in/lbs (20 to 30 cm/kg). See Figure 57.

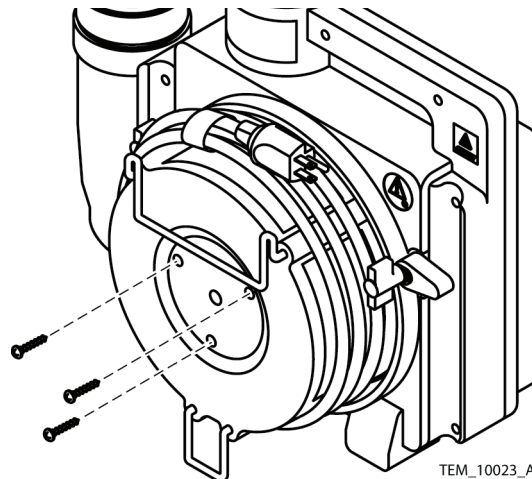

Figure 57. Filter Cover Installation

29. Connect the power cord connector to the warming unit, making sure the connector is fully inserted into the socket in the warming unit housing.
30. Slide the power cord retainer bracket over the power cord connector and tighten the retainer bracket screws until snug.
31. Reseat the power cord into the power cord routing bracket on the filter cover. If necessary, use the head of the flat blade screwdriver to separate the halves of the bracket sufficiently to allow reseating of the cord.

32. Perform the following checks/tests to verify proper operation of the warming unit prior to returning it into service:
- Power Fail / Start Alarm Check* on page 27
 - Thermostat Protection Check* on page 28
 - Output Temperature Check* on page 31
 - Safety Tests* on page 33

Hose Replacement

Table 14. Hose Assembly Components

Qty	Component
1	Hose
1	Nozzle Strap with Clip

Table 15. Tools Required for Replacing Hose Assembly

Tool	Parameter / Use
Wire cutter	Cutting reinforcing wire
Pliers	Bending reinforcing wire



Note:

If the warming system hose is damaged, contact your local Nellcor representative to obtain a replacement hose.



Caution

Only qualified service technicians should replace the hose.

To replace the hose:

- Separate the front and rear covers. See page 38, *Separating the Front and Rear Covers*.
- Locate the end of the hose on the duct adapter.

3. Find the end of the hose's reinforcing wire that is inserted into the locking hole in the duct adapter (Figure 58, item 1).

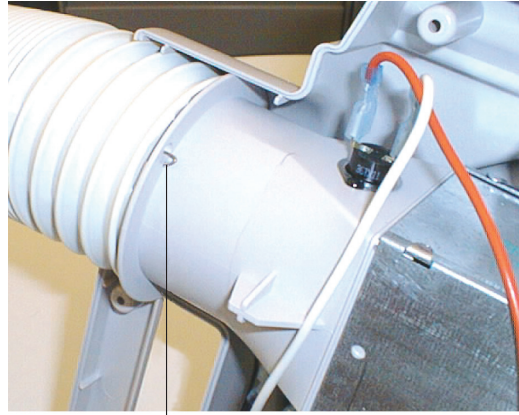

TEM_10087_A

Figure 58. Hose Attachment

4. Straighten the end of the wire and pull it out of the locking hole.
5. Turn the hose counterclockwise to unscrew it from the duct adapter.
6. On the replacement hose, trim the end of the reinforcing wire that is free of the hose material so that approximately 5/8" remains.
7. At a point 1/2" from its free end, bend the wire 90 degrees, so it is perpendicular to the edge of the hose.
8. Put the end of the replacement hose onto the duct adapter.
9. Turn the hose clockwise to screw it onto the duct adapter, until the bent end of the reinforcing wire is aligned with and can easily be placed into the locking hole.
10. Hook the end of the wire through the locking hole, then bend it to secure the hose in place. (See Figure 58.)
11. Remove the nozzle from the end of the old hose and install it onto the free end of the replacement hose. Refer to page 25, *Nozzle Replacement*.
12. Remove the nozzle strap and clip from the old hose and slide it over the nozzle onto the replacement hose.
13. Rejoin the front and rear covers. See page 41, *Rejoining the Front and Rear Covers*.

14. Perform the following checks/tests to verify proper operation of the warming unit prior to returning it into service:

- *Power Fail / Start Alarm Check* on page 27
- *Thermostat Protection Check* on page 28
- *Output Temperature Check* on page 31
- *Safety Tests* on page 33

Duct Adapter Assembly Replacement

Table 16. Duct Adapter Assembly Components

Qty	Component
1	Duct Adapter
2	Screen

Table 17. Tools Required for Replacing Duct Adapter Assembly

Tool	Parameter / Use
Phillips screwdriver	#2 / Removing screws
Allen wrench	3/32" / Adjusting retaining bracket screws
Wire cutter	Cutting cable ties
Knife	Removal of silicone RTV
Silicone RTV	Thermistor connection
Torque driver/wrench	7 to 12 in/lbs (18 to 30 cm/kg)
Flat blade screwdriver	Detaching power cord from filter cover Removing thermostat rivets
Needlenose pliers	Removing thermostat rivets

To replace the duct adapter assembly:

1. Separate the front and rear covers. See page 38, *Separating the Front and Rear Covers*.



Caution

The thermistor is very delicate and easily damaged. Use extreme care when handling, removing, or replacing the thermistor.

- Remove the silicone RTV from the thermistor connection on the duct adapter assembly. See Figure 59.

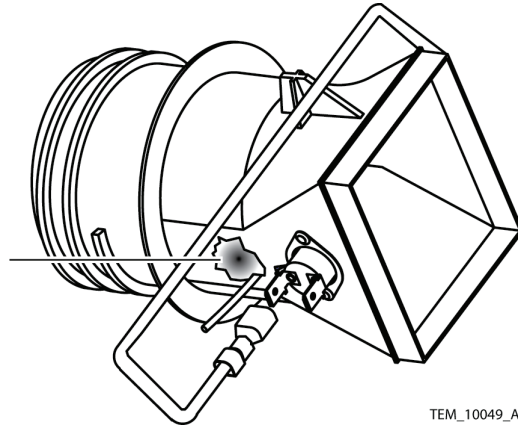

Figure 59. Thermistor Silicone

- Carefully detach the thermistor rivet (Figure 60, item 3) and slide the thermistor (Figure 60, item 2) out of the duct adapter assembly.

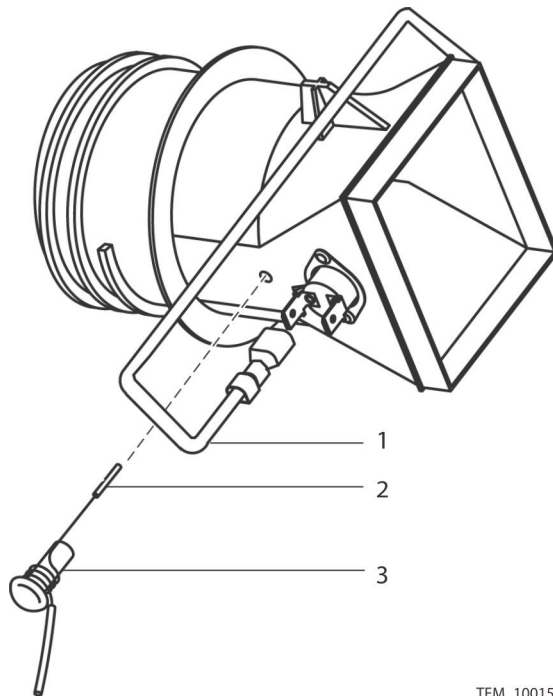

Figure 60. Thermistor Removal

- Detach the wires from the two thermostats on the side of the duct transition. Leave the jumper wire connecting the two thermostats (Figure 60, item 1) in place.

5. Lift the duct adapter assembly out of the rear cover assembly. See Figure 61, item 1.

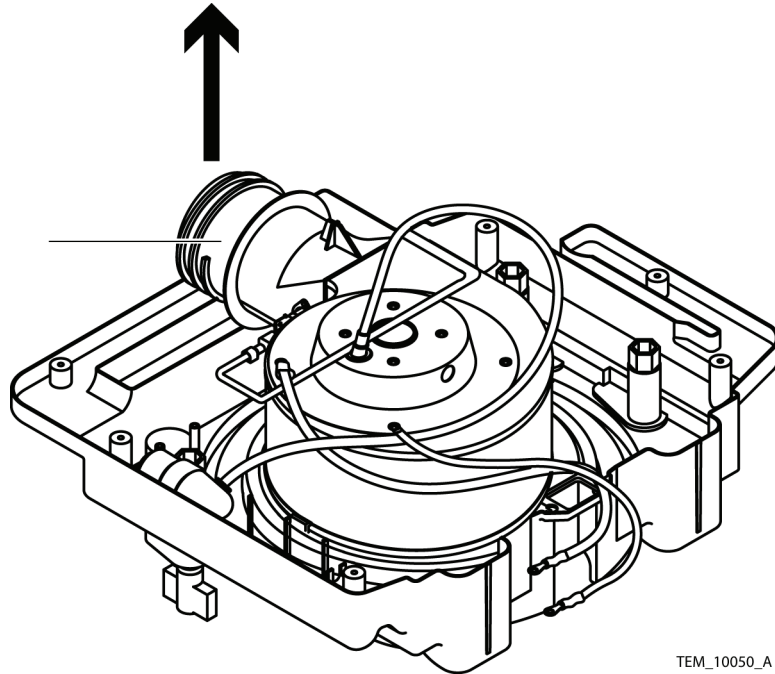

Figure 61. Duct Adapter Removal

TEM_10050_A

6. Using the flat blade screwdriver, reach inside the duct and push the locking pin on each of the plastic rivets holding the thermostats in place downward, so that the pins are flush with the surface of the rivet.
7. Outside the duct, use the needlenose pliers to pull each locking pin upward (out from the duct) until the rivet is loose and pulls free from the duct. **Save the rivets and their locking pins.**
8. Line up the holes in the thermostat mounting flanges with the holes in the replacement duct.
9. Reinstall the plastic rivets, pushing them through the holes in the thermostat mounting flanges into the holes in the replacement duct. Outside the duct, use the flat blade screwdriver to push the locking pins on the rivets inward so that they are flush with the tops of the rivets.
10. Connect the two wires previously attached to the old duct adapter onto the replacement duct adapter, connecting them to the same connection points.

11. Slide the new duct adapter assembly into the blower housing.

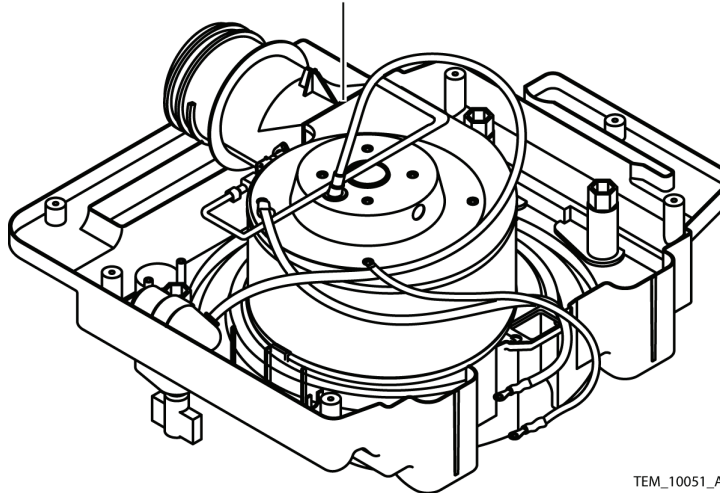

Figure 62. Duct Adapter Placement



Caution

The thermistor is very delicate and easily damaged. Use extreme care when handling, removing or replacing the thermistor.

12. Carefully reinsert the thermistor into the duct adapter assembly. See Figure 60, item 1.



Note:

Position the thermistor as shown.

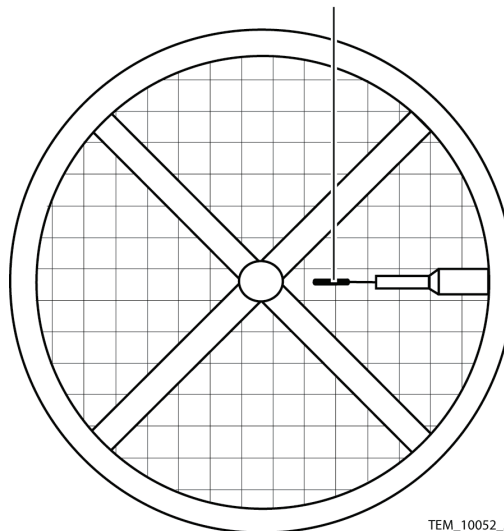

Figure 63. Thermistor Position Within Duct Adapter

13. Apply a small amount of silicone RTV to the thermistor rivet cap and the adapter housing. See Figure 59.
14. Rejoin the front and rear covers. See page 41, *Rejoining the Front and Rear Covers*.
15. Perform the following checks/tests to verify proper operation of the warming unit prior to returning it into service:
 - a. *Power Fail / Start Alarm Check* on page 27
 - b. *Thermostat Protection Check* on page 28
 - c. *Output Temperature Check* on page 31
 - d. *Safety Tests* on page 33

Rear Cover Assembly Replacement

Table 18. Rear Cover Assembly Components

Qty	Component
1	Rear Enclosure
1	Cable Clamp
1	Cable Tie
3	Lag Bolts, 3¼
1	Test Cover
1	Screw
1	Heater Cone Insert
1	Heater Screen
1	Attention Label
3	Knob, IV Pole Clamp
3	IV Pole Clamp Assembly
1	Caution Label

Table 19. Tools Required for Replacing Rear Cover Assembly

Tool	Parameter / Use
Phillips screwdriver	#2 / Removing screws
Allen wrench	3/32" / Adjusting retaining bracket screws
Wire cutter	Cutting cable ties
Socket	10 mm
Torque driver/wrench	4 to 12 in/lbs (10 to 30 cm/kg)
	36 to 44 in/lbs (91 to 112 cm/kg)
Flat blade screwdriver	Detaching power cord from filter cover

To replace the rear cover assembly:

1. Unplug the warming system power cord from the AC outlet.
2. Lay the warming unit on its front side, so that the bottom of the unit is visible.

3. Remove the filter cover screws from the warming unit. See Figure 64.

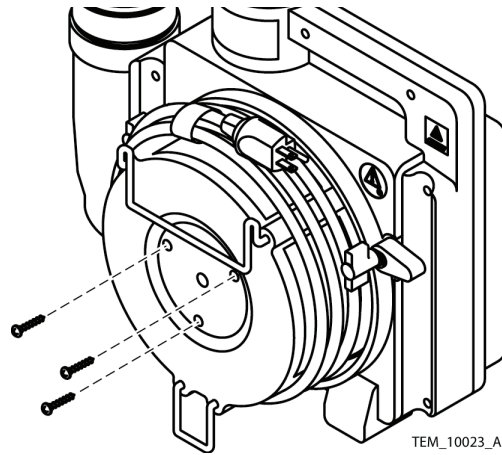

Figure 64. Filter Cover Screws

4. Loosen the retaining bracket screws slightly, so that the retaining bracket can be pulled away from the power cord connector.
5. Unseat the power cord from the power cord routing bracket on the filter cover. If necessary, use the head of the flat blade screwdriver to separate the halves of the bracket sufficiently to allow unseating of the cord.
6. Disconnect the power cord connector from the warming unit.
7. Remove the filter cover assembly from the warming unit.
8. Remove the filter from the rear cover assembly. See Figure 65.



Figure 65. Filter Removal

9. Separate the front and rear covers. See page 38, *Separating the Front and Rear Covers*.



Note:

Perform steps 10 through 19 if complete separation of the front and rear halves of the unit is desired or necessary. Otherwise, skip to step 20.

10. Cut the two cable bundle ties. See Figure 66, items 1 and 2.

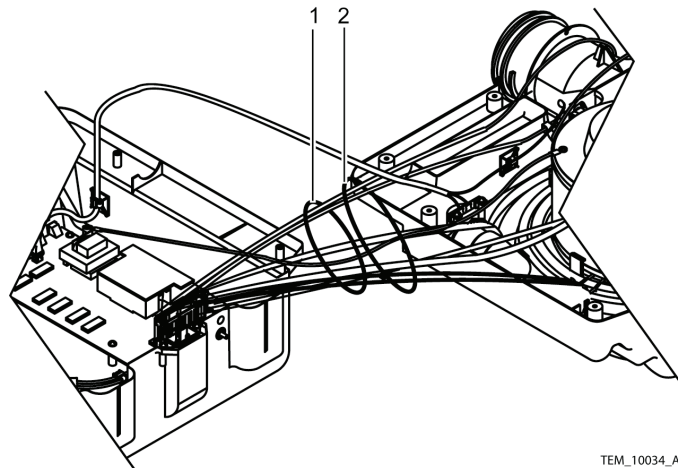

TEM_10034_A

Figure 66. Separated Covers

11. Disconnect the 9-pin connector from the Control PCB (Figure 67, item 1).

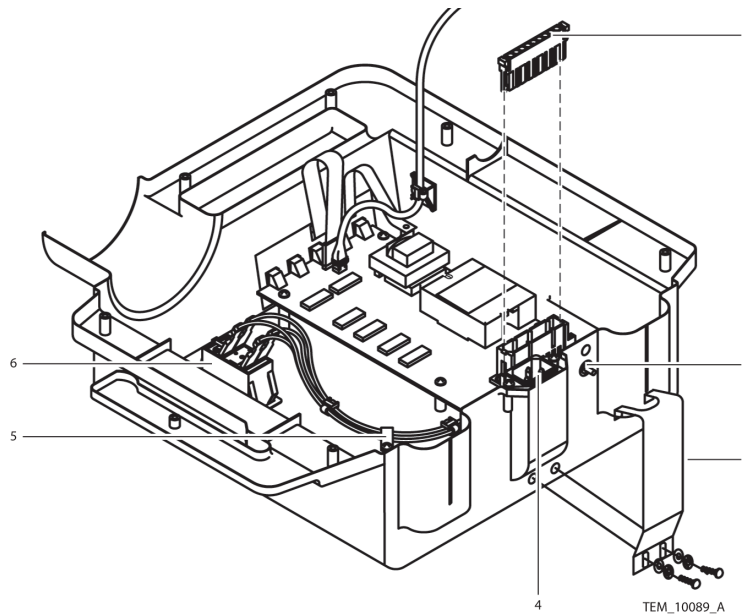

TEM_10089_A

- | | | | |
|---|-------------------------------|---|--------------------|
| 1 | 9-Pin Connector | 4 | AC Power Connector |
| 2 | Equipotential Ground Terminal | 5 | Cable Clamp |
| 3 | Power Cord Retaining Bracket | 6 | Power Switch |

Figure 67. Front Cover Assembly

12. Disconnect the wires from the equipotential ground stud (Figure 67, item 2).
13. Remove the AC power connector from the front cover assembly (Figure 67, item 4).
14. Remove the cable clamp from the front cover assembly (Figure 67, item 5).

Caution

Write down the color code of each wire connected to the power switch. This will ensure that the wires will be reconnected properly.

15. Disconnect the four wires from the power switch (Figure 67, item 6).
16. Cut the cable tie securing the thermistor cable to the front cover assembly (Figure 68, item 1).

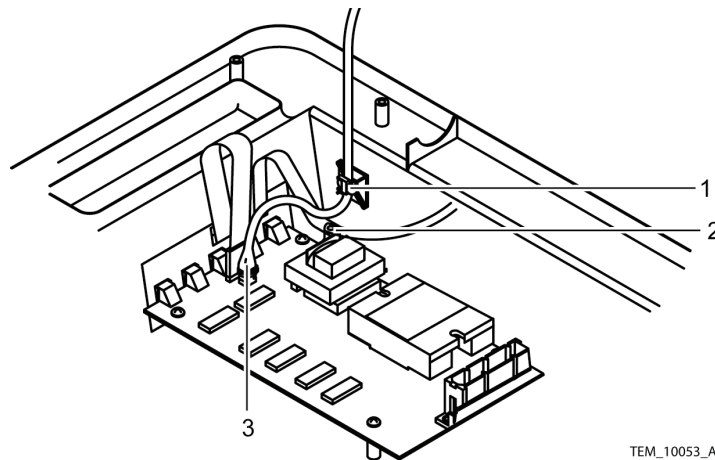

Figure 68. Cable Disconnect

17. Remove the ground screw. See Figure 68, item 2.
18. Disconnect the thermistor cable connector. See Figure 68, item 3.
19. Place the front cover assembly in a safe place.

Caution

The thermistor is very delicate and easily damaged. Use extreme care when handling, removing or replacing the thermistor.

20. Remove the thermistor cable terminal board (Figure 69, item 2).

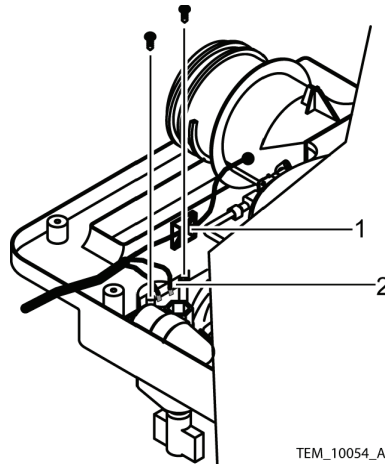

Figure 69. Thermistor Cable Removal

21. Cut the cable tie securing the thermistor cable to the rear cover assembly (Figure 69, item 1).



Note:

The blower assembly is held onto the rear cover assembly by four screws and four clips. It is easier for two people to release the clips and lift the blower assembly from the rear cover assembly.

22. Remove the screws holding the blower assembly to the rear cover assembly. See Figure 70.

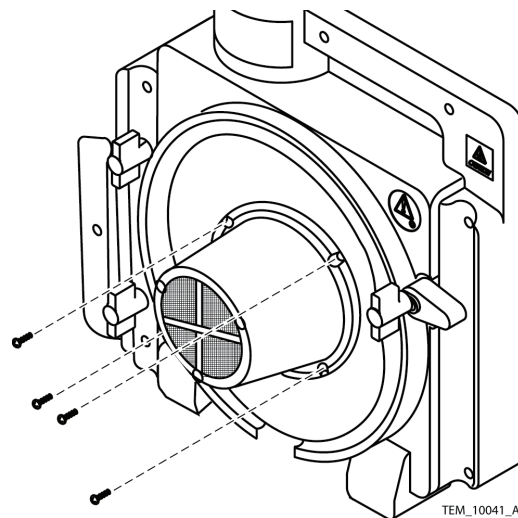

Figure 70. Blower Assembly Screws

23. Loosen the nut holding the capacitor to the rear cover assembly. See Figure 71.

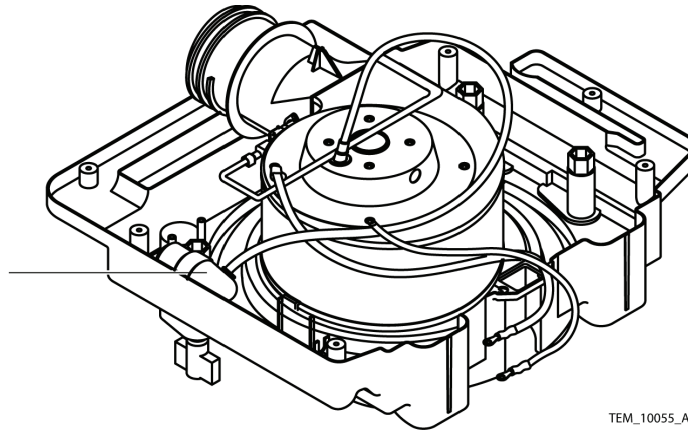

Figure 71. Blower Capacitor

24. Cut the cable tie and lift the capacitor free of the rear cover assembly.



Note:

The thermistor cable is fragile. When handling the adapter duct, apply as little tension as possible to the thermistor cable to avoid damaging wires or its mechanical connection to the duct.

25. Carefully pull the adapter duct up to remove it from the blower outlet.
Take care not to pull the thermistor cable out of the adapter duct when removing the duct from the outlet.
26. Rotate the blower motor assembly clockwise to disengage two of the four clips. See Figure 72 and Figure 73.

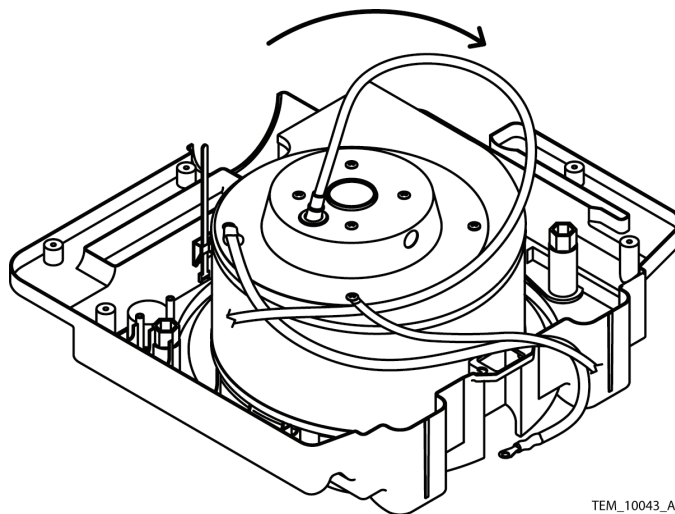

Figure 72. Blower Motor Removal

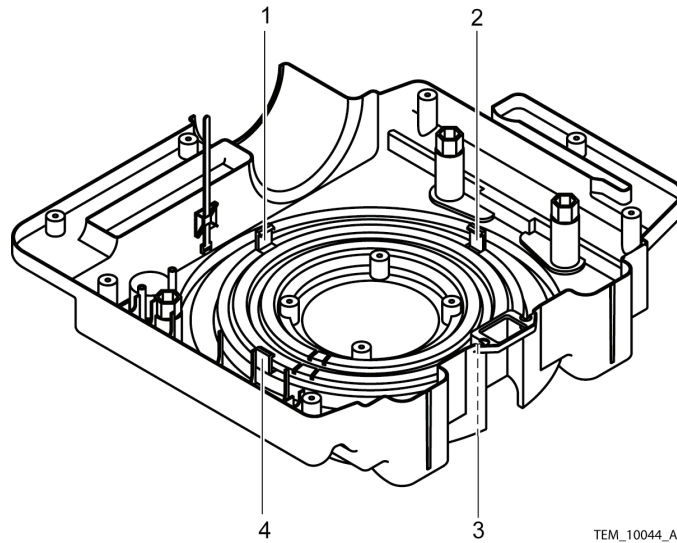

Figure 73. Blower Assembly Clips

TEM_10044_A

27. Slide the blower motor assembly away from the engaged clips to disengage them.
28. Remove the rubber gasket from the rear cover assembly.

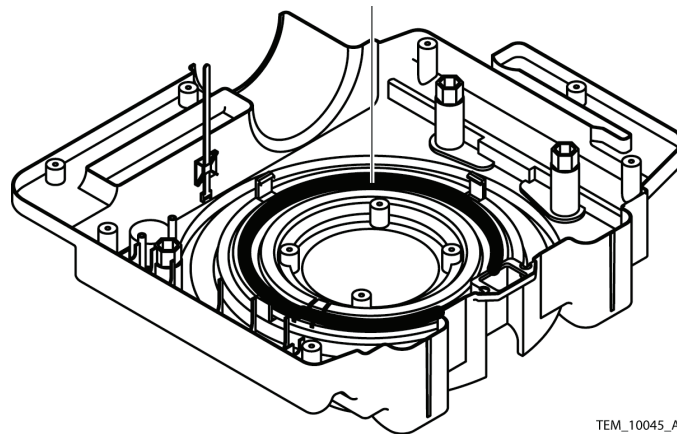

Figure 74. Rubber Gasket

TEM_10045_A



Caution

Do not touch the heater coil. Body oil can cause damage to the heater coil when it is in use.

29. Lift the heater assembly (Figure 75, item 1) out of the rear cover assembly.

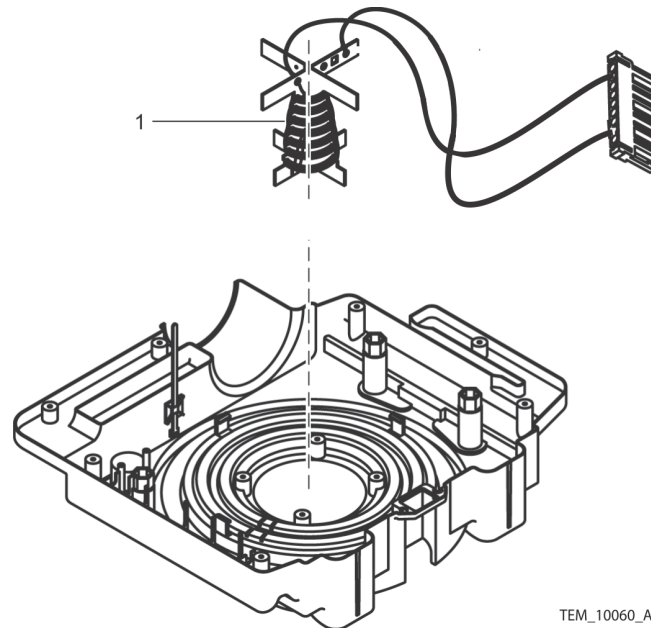

Figure 75. Heater Assembly

30. Discard the old rear cover assembly, including the heater cone insert, heater screen, and mounting clamps.



Note:

Ensure that the heater temperature sensor (Figure 76, item 1) is oriented upward when reinstalling the heater in the rear cover assembly.

31. Slide the heater into the replacement rear cover assembly (see Figure 76).

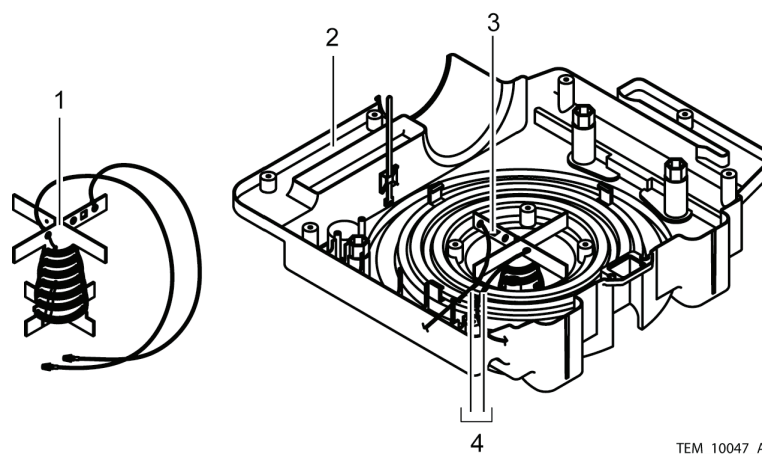

Figure 76. Heater Assembly Installation

32. Route the wires from the heater through the cut-outs in the rear cover assembly. See Figure 76, item 4.
33. Place the rubber gasket into the rear cover assembly with the wire indentations over the heater wires. See Figure 77.

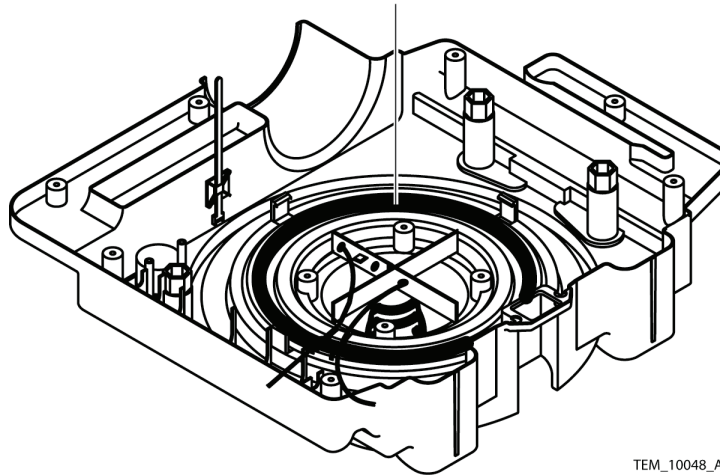

Figure 77. Rubber Gasket

34. Place the blower assembly into the rear cover assembly and ensure that the blower assembly clips attach over the edges of the blower assembly.

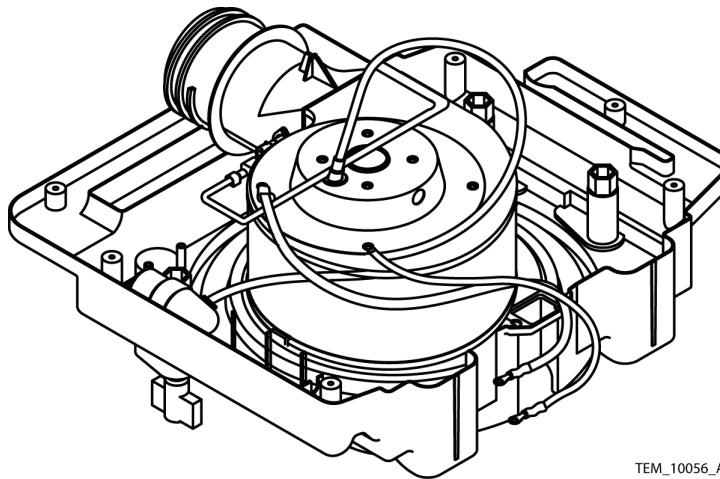

Figure 78. Blower Installation



Note:

The thermistor cable is fragile. When handling the adapter duct, apply as little tension as possible to the thermistor cable to avoid damaging wires or its mechanical connection to the duct.

35. Carefully place the square end of the adapter duct into the blower outlet and snap the duct into place, taking care not to damage the thermistor cable.
36. Install the blower assembly mounting screws into the rear cover assembly. Tighten the screws to 4 to 6 in/lbs (10 to 15 cm/kg). See Figure 79.

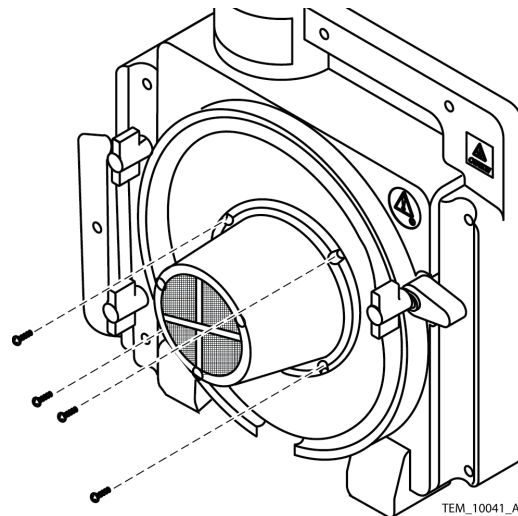

Figure 79. Blower Screws

37. Install the thermistor cable terminal board (Figure 80, item 2). Tighten the screw to 4 to 6 in/lbs (10 to 15 cm/kg).

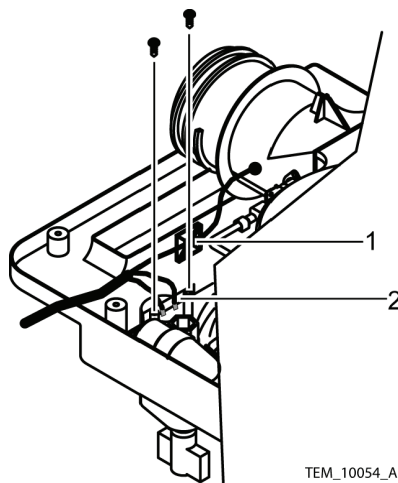

Figure 80. Thermistor Cable Installation

38. Install a cable tie around the thermistor cable and the cable tie mount on the rear cover assembly (Figure 80, item 1).



Caution

Do not overtighten the capacitor nut. Overtightening the capacitor nut will cause the plastic rib to crack.

39. Install the capacitor in the rear cover assembly and tighten the nut to 7 to 10 in/lbs (18 to 25 cm/kg). See Figure 81.

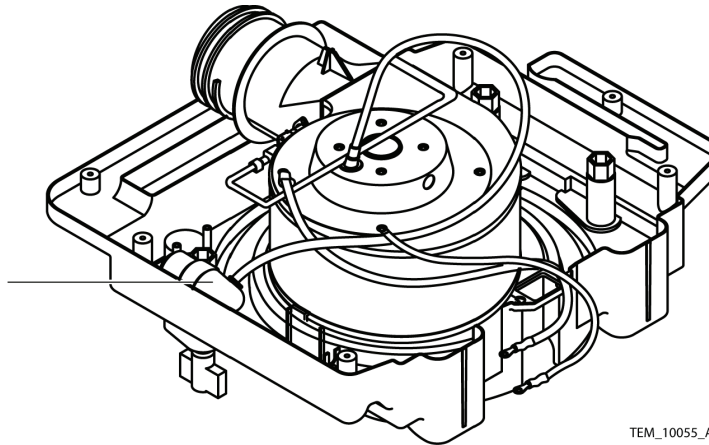

TEM_10055_A

Figure 81. Capacitor Installation

40. Install the cable tie around the capacitor. See Figure 81.



Note:

Perform steps 41 through 50 only if steps 10 through 19 were performed earlier, and the front and rear halves of the warming unit have been completely detached from each other. If steps 10 through 19 were not performed, skip to step 51.

41. Connect the thermistor cable to the Control PCB.

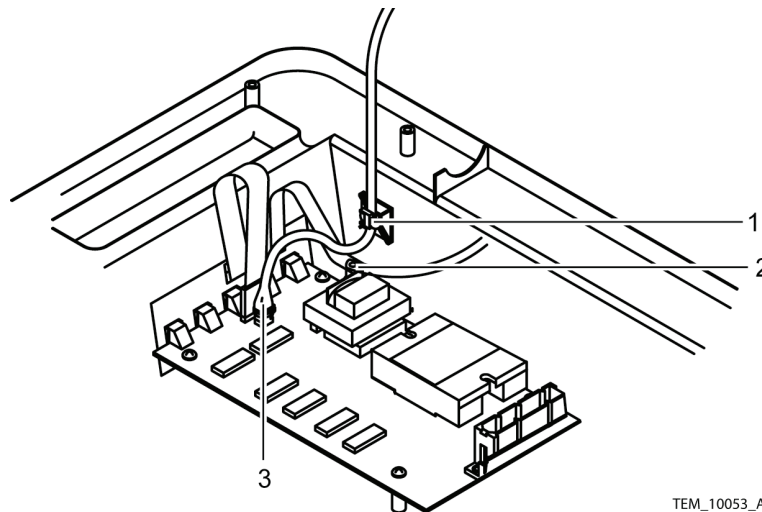

TEM_10053_A

Figure 82. Cable Connections

42. Install a cable tie around the thermistor cable connector (Figure 82, item 3) and Control PCB connector to secure the thermistor cable to the PCBA.
43. Connect the key pad ground strap and the blower ground wire (Figure 82, item 2). Tighten the screw to 4 to 6 in/lbs (10 to 15 cm/kg).
44. Install a cable tie around the thermistor cable and the cable tie mount (Figure 82, item 1) to secure the thermistor cable to the front cover.
45. Connect the four wires to the power switch. Make sure to reconnect the wires in the same way they were connected before; refer to the list of wire colors and where they were connected to the switch, as recorded in Step 15. See Figure 83, item 6.

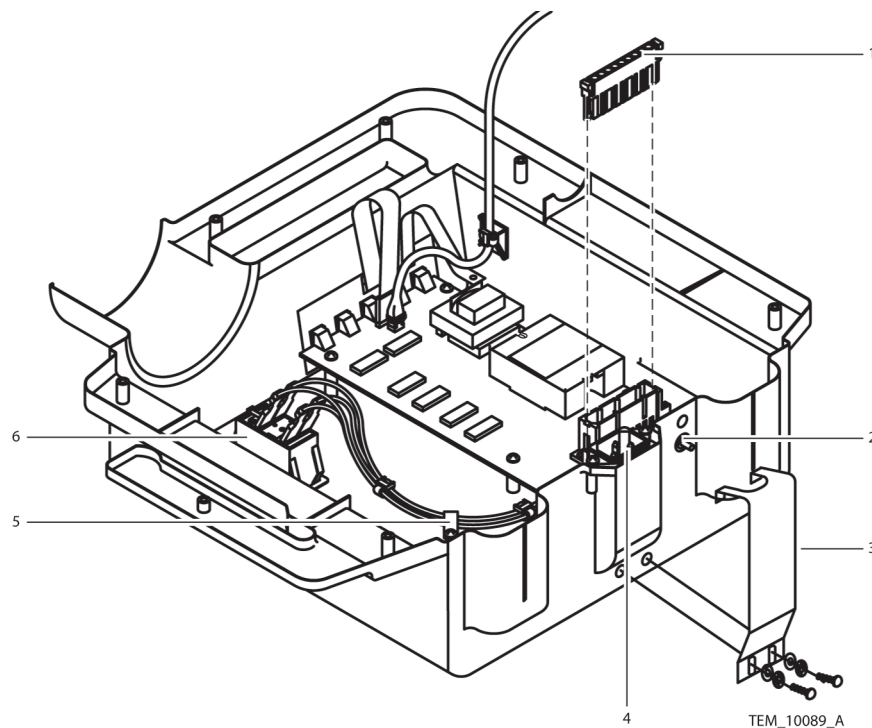

Figure 83. Front Cover Assembly

46. Install the cable clamp around the power switch wires (Figure 83, item 5).
47. Install the AC power connector into the front cover assembly. Tighten the screws to 4 to 6 in/lbs (10 to 15 cm/kg). See Figure 83, item 4.
48. Connect the 9-pin connector to the Control PCB (Figure 83, item 1).

49. Connect the ground wires to the equipotential ground stud (Figure 84, item 2) in the order shown in Figure 84. Tighten the nuts to 36 to 44 in/lbs (91 to 112 cm/kg).

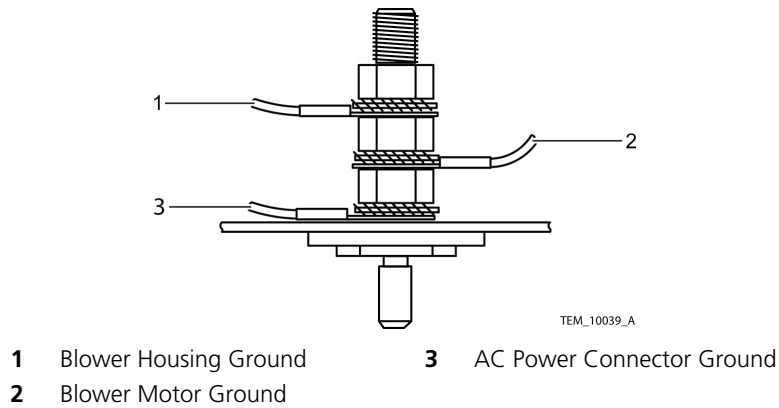

Figure 84. Equipotential Ground Stud Wiring

50. Install the cable harness bundle ties. See Figure 85, items 1 and 2.

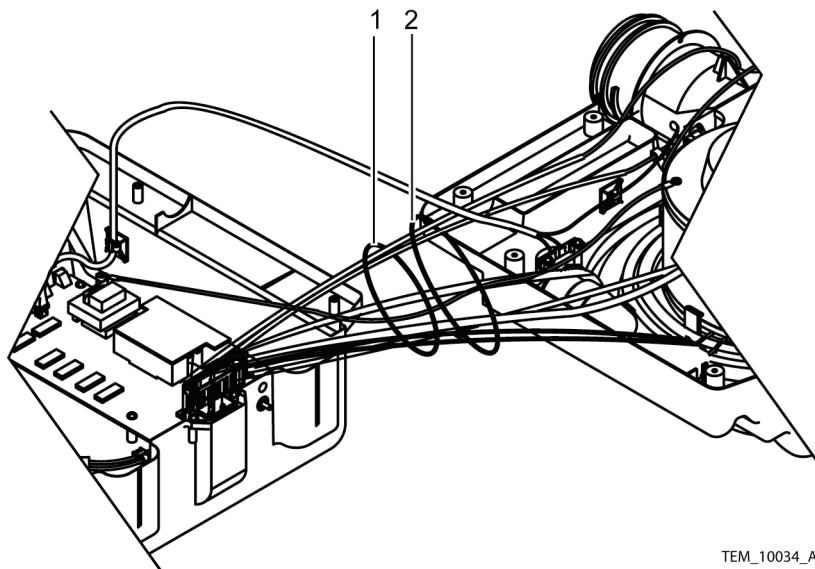

Figure 85. Cable Harness Bundle Ties

51. Rejoin the front and rear covers. See page 41, *Rejoining the Front and Rear Covers*. However, do not reattach the power cord until after reattaching the filter cover (step 53).

52. Place the filter into the rear cover assembly.



Figure 86. Filter Installation

53. Install the filter cover assembly on the rear cover assembly. Tighten the screws to 8 to 12 in/lbs (20 to 30 cm/kg). See Figure 87.

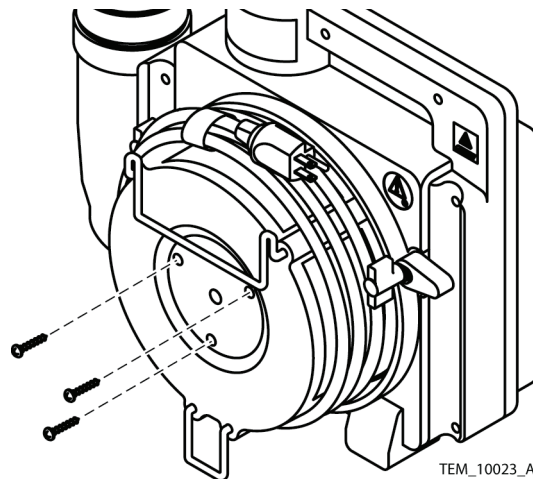

Figure 87. Filter Cover Installation

54. Connect the power cord connector to the warming unit, making sure the connector is fully inserted into the socket in the warming unit housing.
55. Slide the power cord retainer bracket over the power cord connector and tighten the retainer bracket screws until snug.
56. Reseat the power cord into the power cord routing bracket on the filter cover. If necessary, use the head of the flat blade screwdriver to separate the halves of the bracket sufficiently to allow reseating of the cord.

57. Perform the following checks/tests to verify proper operation of the warming system prior to returning it into service:

- *Safety Tests* on page 33
- *Thermostat Protection Check* on page 28
- *Output Temperature Check* on page 31
- *Safety Tests* on page 33

Spare Parts & Accessories

Overview

This chapter provides information on spare parts and accessories for the WarmTouch™ Model WT-5300A patient warming system, as well as how to order them.

Ordering Information

The warming system and blankets may be ordered from Nellcor Technical Services (1.800.635.5267) or your local representative.

Table 20. Spare Parts and Accessories

Description	Item Number Figure 88	Item Number Figure 89	Part Number
AC Inlet / EMI Filter		21	SP10009142
AC Power Switch / Breaker		23	169-1201SP
Blower Assembly (120V)		19	SP10016697
Cart	3		5022900
Control Panel		13	SP129-9012
Duct Adapter Assembly		18	168-0205SP
Filter Cover Assembly	8		168-0202SP12
Front Cover Assembly	2	2	168-0201SP2
Fuse, 0.32 amps		14	169-5800
Heater Assembly (120V)		20	10013662SP
HEPA Filter (5900)	9		502-2200
Hose	1		502-2000
I.V. Clamp and Foot	4		168-0203SP
I.V. Clamp Knob	5		168-2005SP
Nozzle	11		502-2100
Nozzle Strap with Clip	12		SP312-0070
PCB, 5300A WT		22	SPGR100307
Power Cord (NA)	7		502-2400
Rear Cover Assembly	6	6	168-0200SP12
Strap, Hook and Loop	10		168-2023
Thermostat, Disc 50° 2EA		17	SP168-0220
Thermistor Assembly		15	SP169-0211

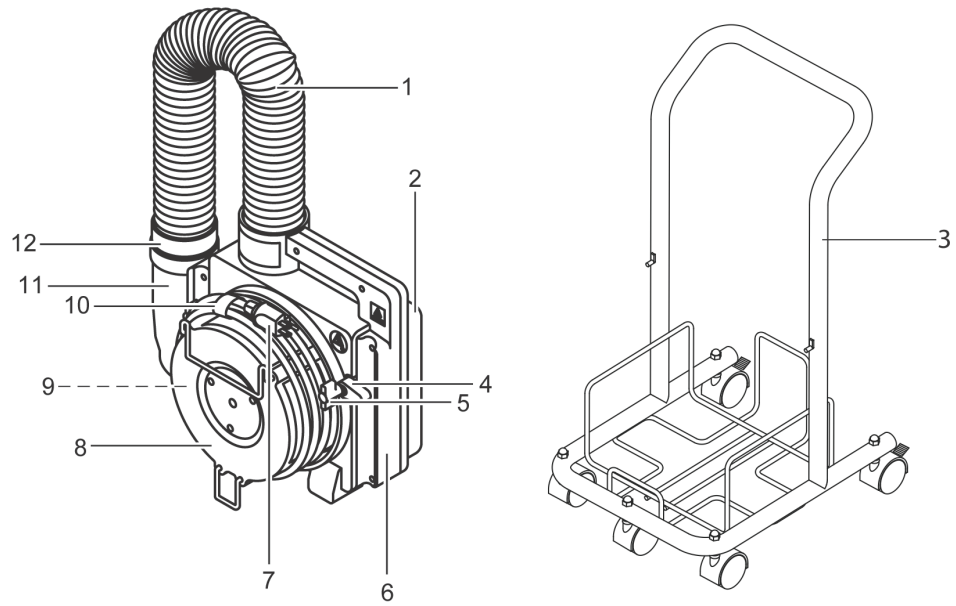

Figure 88. Spare Parts (Sheet 1)

TEM 10017 A

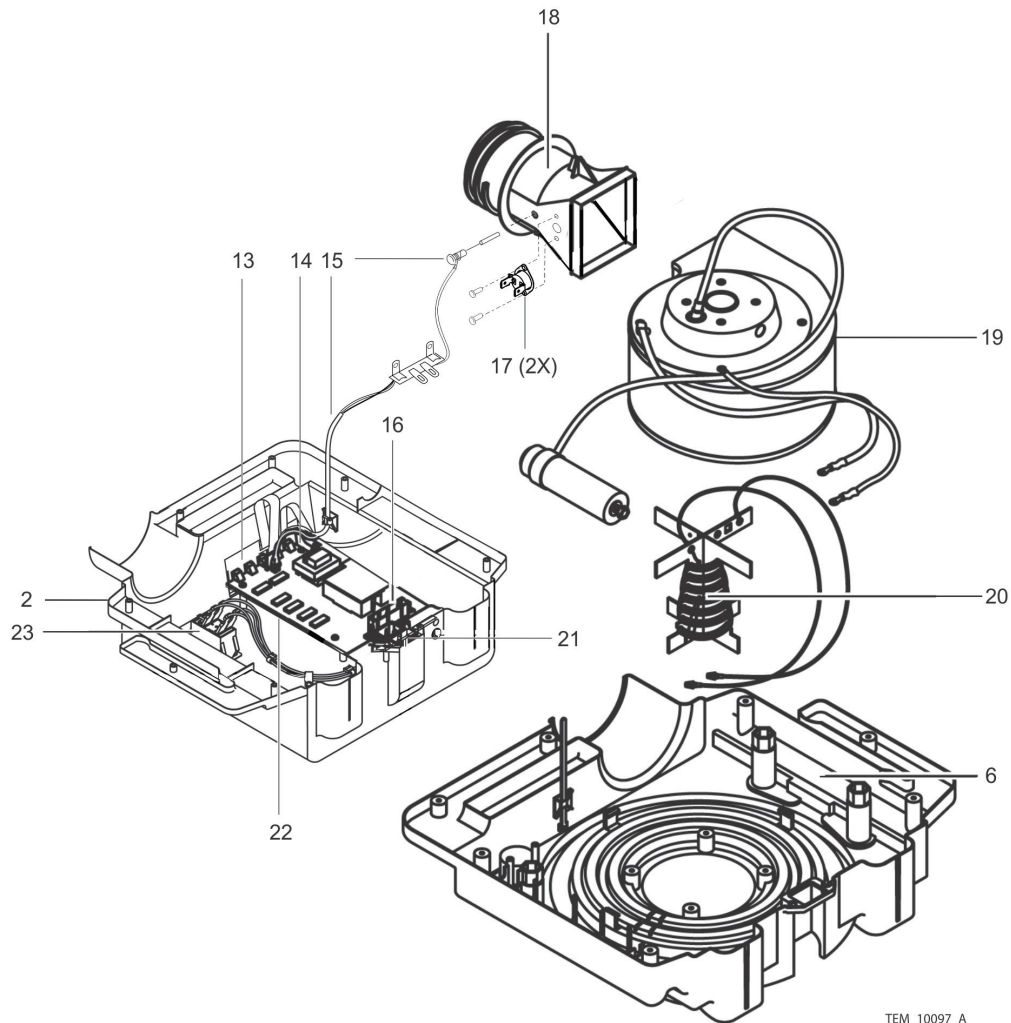

Figure 89. Spare Parts (Sheet 2)

TEM_10097_A

Replacement Parts and Accessories

Warming system replacement parts and accessories are listed on the Internet at:

<http://www.nellcor.com/serv/GenParts.aspx>

Manual Availability

The most recent revision of this manual is available on the Internet at:

<http://www.nellcor.com/serv/manuals.aspx>

Packing for Shipment

Overview

To ship the WarmTouch™ Model WT-5300A patient warming system for any reason, follow the instructions in this chapter.

Returning the Warming Unit

Prior to shipping the warming unit, contact Nellcor Technical Services or your local Nellcor representative for shipping instructions, including a Returned Goods Authorization (RGA) number. Mark the shipping carton and any shipping documents with the RGA number.

Return the warming unit by any shipping method that provides proof of delivery.

If possible, ship the warming unit in its original shipping carton. If the original carton is not available, use a suitable carton with appropriate packing material to protect the warming unit during shipping. North American customers may also contact the Nellcor Technical Services Department to obtain a replacement shipping carton.

Pack the warming unit carefully. Failure to follow the packing instructions in this section may result in loss or damage not covered by any applicable Nellcor warranty.

Repacking in Original Carton

If available, use the original carton and packing materials. See Figure 90.

**Note:**

Use tape or staples on the packing inserts to ensure they retain their form.

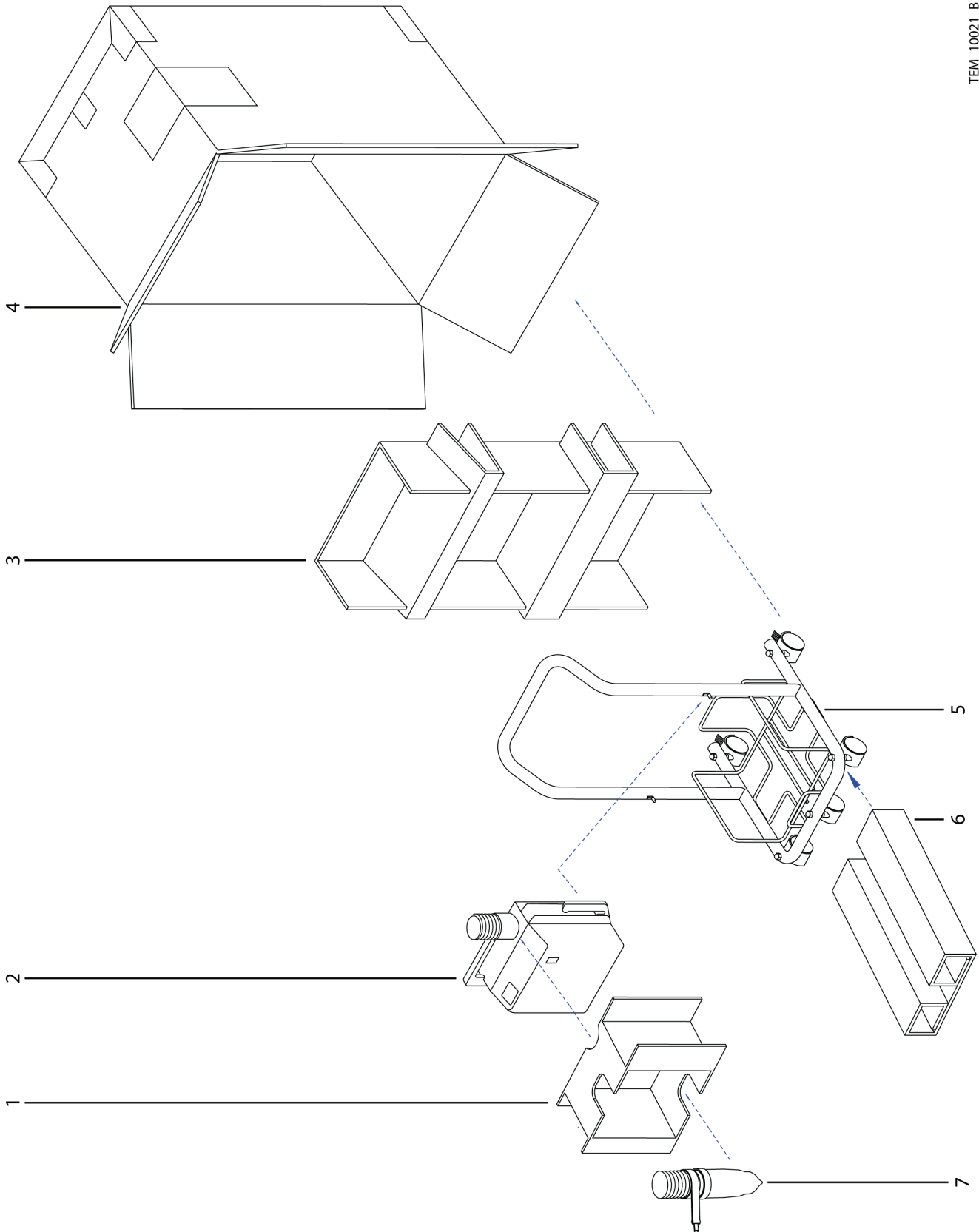

Figure 90. Packing the Warming Unit in Original Carton

To pack the warming unit (refer to Figure 90):

1. Place the full length insert (item 3) into the box (item 4), with the wide side gap on the right.
2. Slide the base support insert (item 6) into the bottom of the box, with the ribs facing up.
3. Make sure the warming unit (item 2) is mounted onto the cart (item 5). Refer to the *WT-5300A Patient Warming System Operator's Manual* for details.
4. Slide the warming unit and cart into the box, with the handle to the rear and the bottom of the cart frame resting on the base support insert.
5. Place the hose insert (item 1) over the warming unit, with the wide flange on the right side and the shallow cutout resting against the hose outlet.
6. Route the collapsed hose from the blower and set the nozzle end (item 7) into the two deep cutouts in the hose insert. The nozzle should be in the lower of the two cutouts, above the cart base.
7. Seal carton with packing tape.
8. Label carton with shipping address, return address, and RGA number.

Repacking in a Different Carton

If the original carton is not available, use the following procedure to pack the warming unit:

1. Locate a corrugated cardboard shipping carton with a bursting strength of at least 200 pounds per square inch (psi).
2. Fill the bottom of the carton with at least 2 inches of packing material.
3. Place the warming unit on the layer of packing material and fill the box completely with packing material.
4. Seal carton with packing tape.
5. Label carton with the shipping address, return address, and RGA number.

Page Left Intentionally Blank

Specifications

Overview

This chapter contains physical and operating specifications for the WarmTouch™ Model WT-5300A patient warming system.

Warming System Specifications

No special transport or storage methods are required for the WarmTouch™ Model WT-5300A patient warming system.

Table 21. System Specifications

Warming Blanket Specifications	
Maximum blanket surface temperature	44°C
Blower Specifications	
Dimensions	38 cm x 41 cm x 28 cm (15 inches x 16 inches x 11 inches)
Weight	6.8 kgs (15 lbs.)
Power Requirements	120 VAC, 50 - 60 Hz, 10 A
Automatic Temperature Stepdown (Boost to High Temperature)	After 45 minutes of continuous use blower will step down from Boost to High setting.
Power Supply Cord	4.26 m (14 feet)
Thermal Protection	Thermostat (internal): 47°C - 50°C (117°F - 122°F)
Ambient Blower Operating Temperature Range	18°C - 28°C (64.4°F - 82.4°F)
Over Temperature Alarm Level	65 dB at 3 meters
Protection Against Ingress of Fluids	Ordinary
Cart Specifications	
Weight	3.1 kg (6.8 pounds)
Height	67.1 cm (26.4 inches)
Width	32.3 cm (12.7 inches)
Depth	38.6 cm (15.2 inches)

Transport and Shipping in Shipping Container

Table 22. Shipping Container Specifications

Temperature	-40°C to 70°C (-40°F to 158°F)
Altitude	-390 m to 6,096 m (-1,280 ft. to 20,000 ft.)
Barometric Pressure	500 hPa to 1,060 hPa (375 mmHg to 795 mmHg)
Relative Humidity	15% to 95% (non-condensing)

Compliance

Table 23. Compliance Standards

Item	Compliant With
Equipment classification	IEC/EN 60601-1 2nd edition CSA C22.2 No. 601.1 M90 UL 60601-1 1st edition IEC 60601-2-35: 1996 EN 60601-2-35: 1997
Type of protection	Class I (on AC power)
Degree of protection	Type BF - Applied part
Mode of operation	Continuous
Electromagnetic Compatibility	IEC/EN 60601-1-2 3rd edition

Manufacturer's Declaration



WARNING

The use of accessories and cables other than those specified may result in increased emission and/or decreased immunity of the warming system.

The warming system is suitable for use in the specified electromagnetic environment. The customer and/or user of the warming system should ensure it is used in the prescribed electromagnetic environment.

Electromagnetic Compatibility (EMC)

Electromagnetic Emissions

Table 24. Electromagnetic Emissions Guidelines

Emissions Test	Compliance	Electromagnetic Environment Guidance
RF emission CISPR 11	Group 1, Class A	The warming system uses RF energy only for its internal function. Therefore, its RF emissions are very low and not likely to cause any interference in nearby electronic equipment.

Electromagnetic Immunity

These guidelines may not apply in all situations. Electromagnetic propagation is affected by absorption and reflection from structures, objects, and people.

Table 25. Electromagnetic Immunity Guidelines

Immunity Test	EN 60601-1-2 Test Level	Compliance Level	Electromagnetic Environment Guidance
Electrostatic discharge (ESD) IEC/EN 61000-4-2	±6 kV contact ±8 kV air	±6 kV contact ±8 kV air	Floor should be wood, concrete, or ceramic tile. If floors are covered with synthetic material, the relative humidity should be at least 30%.
Electric fast transient/burst IEC/EN 61000-4-4	±2 kV for power supply lines ±1 kV for input/output lines	±2 kV for power supply lines ±1 kV for input/output lines	Mains power quality should be that of a typical commercial and/or hospital environment.
Surge IEC/EN 61000-4-5	±1 kV differential mode ±2 kV common mode	±1 kV differential mode ±2 kV common mode	Mains power quality should be that of a typical commercial and/or hospital environment.

Table 25. Electromagnetic Immunity Guidelines (Continued)

Immunity Test	EN 60601-1-2 Test Level	Compliance Level	Electromagnetic Environment Guidance
Voltage dips, short interruptions and voltage variations on power supply IEC/EN 61000-4-11	<5% U_T (>95% dip in U_T) for 0.5 cycle	<5% U_T (>95% dip in U_T) for 0.5 cycle	Mains power quality should be that of a typical commercial and/or hospital environment. If the user of the warming system requires continued operation during power mains interruption, it is recommended that the warming system be powered from an uninterruptible power supply or battery. Note: U_T is the AC mains voltage prior to application of the test level.
	40% U_T (60% dip in U_T) for 5 cycles	40% U_T (60% dip in U_T) for 5 cycles	
	70% U_T (30% dip in U_T) for 25 cycles	70% U_T (30% dip in U_T) for 25 cycles	
	<5% U_T (95% dip in U_T) for 5 sec.	<5% U_T (95% dip in U_T) for 5 sec.	
Power frequency (50/60 Hz) magnetic field IEC/EN 61000-4-8	3 A/m	3 A/m	It may be necessary to position the warming system further from the sources of power frequency magnetic fields or to install magnetic shielding. The power frequency magnetic field should be measured in the intended installation location to assure that it is sufficiently low.

For transmitters rated at a maximum output power not listed, estimate the separation distance using the equation in the corresponding column, where P is the maximum output (power rating of the transmitter in watts [W]) according to the transmitter manufacturer.

Note:

Portable and mobile RF communications equipment should be used no closer to any part of the warming system, including cables, than the recommended separation distance calculated from the equation appropriate for the frequency of the transmitter.

Table 26. Recommended Separation Distances

	Frequency of Transmitter		Equation for Separation Distance
Radiated RF EN 61000-4-3	3 V/m 80 MHz 800 MHz	3 V/m	Distance = $0.35\sqrt{P}$ 80 MHz to 800 MHz
	3 V/m 800 MHz 2.5 GHz	3 V/m	Distance = $0.7\sqrt{P}$ 800 MHz to 2.5 GHz
Conducted RF EN 61000-4-6	3 Vrms 150 kHz 80 MHz	3 Vrms	Distance = $1.2\sqrt{P}$ 150 kHz to 80 MHz
Rated Maximum Output Power of Transmitter in Watts	Separation Distance in Meters According to Transmitter Frequency		
	150 kHz to 80 MHz	80 MHz to 800 MHz	800 MHz to 2.5 GHz
0.010	0.120	0.035	0.070
0.100	0.380	0.110	0.220
1.000	1.200	0.350	0.700
10.000	3.800	1.120	2.210
100.000	12.000	3.500	7.000

Ground Integrity Test

Without power cord: $\leq 100 \text{ m } \Omega$

With power cord: $\leq 200 \text{ m } \Omega$

Earth Leakage Current Test

Table 27. Earth Leakage Current Test

AC Polarity	Line Cord	Neutral Cord	Leakage Current
Normal	Closed	Closed	500 μ A
Reversed	Closed	Closed	500 μ A
Normal	Open	Closed	1000 μ A
Normal	Closed	Open	1000 μ A

Enclosure Leakage Current Test

Table 28. Enclosure Leakage Current Test

AC Line Cord	Neutral Line Cord	Power Line Ground Cable	AAMI / ANSI Standard ES1
Normal	Closed	Closed	100 μ A
Normal	Closed	Open	500 μ A
Normal	Open	Closed	500 μ A
Reversed	Closed	Closed	100 μ A
Reversed	Open	Closed	500 μ A
Reversed	Closed	Open	500 μ A

Principles of Operation

Overview

This chapter provides information on various circuits and other components of the WarmTouch™ Model WT-5300A patient warming system.

Control Panel

The control panel features four manually switched temperature settings, as well as a warning light (see Figure 91). The selected temperature is indicated by an LED indicator.

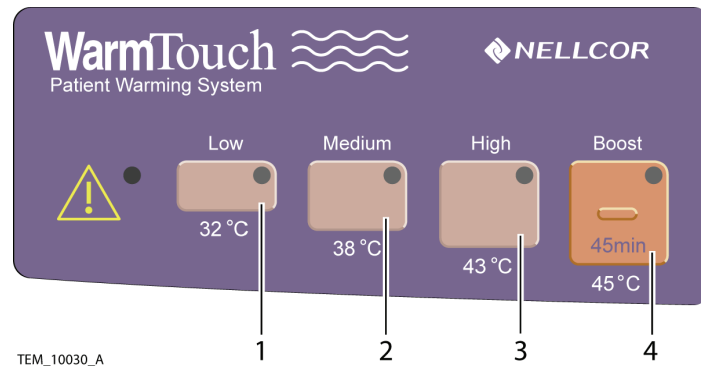

Figure 91. Control Panel

Each temperature setting represents the average temperature of air at the duct inlet. The four temperature settings are:

- Low: 30°C (89.6°F)
- Medium: 38°C (100.4°F)
- High: 43°C (109.4°F)
- Boost: 45°C (113°F) for 45 minutes

The warning light on the control panel indicates that the warming system has detected a fault. When the warning light is lit, the warming system will also

sound an alarm. See page 15, *Alarms* for a detailed description of the alarm system.

Main Circuit Board

See Figure 93 and Figure 94 at the end of this chapter for the schematic diagram of the warming unit main circuit board. The main circuit board consists of:

- DC power supply circuit
- Control logic circuit
- Automatic temperature stepdown
- Alarm driver circuits
- Temperature control circuit
- Liquid crystal display (LCD) hour meter

There are three connectors on the main circuit board:

- J1 – connects the main circuit board to the control panel
- J2 – connects the main circuit board to the AC power line circuit, the heater, and the blower
- J3 – connects the temperature control circuit of the main circuit board to:
 - YS1 400 series thermostat
 - Over-temperature test port

DC Power Supply Circuit

The 100 - 120 VAC enters the main circuit board through J2, pins 3 and 4. The power supply circuit consists of:

- F1 fuse, located in the primary of the transformer
- D7 bridge rectifier
- VR1 12 VDC voltage regulator

**WARNING**

Dangerous voltages (100 - 120 VAC) are exposed during this procedure. Exercise extreme care not to come in contact with the 100 - 120 VAC.

In case of warming system failure (no lights), the presence of 12 VDC should be verified. This can be done by opening the warming system. Refer to page 38, *Separating the Front and Rear Covers*.

Connect a voltmeter to test points TP3 and TP4 (TP3 is 12 VDC; TP4 is ground). Both test points are located on the circuit board assembly directly below the transformer (T1).

Control Logic Circuit

The control logic circuit for temperature settings consists of:

- U1 and U2 logic gates
- U4 inverter
- U3 dual R-S latch
- U5 quad switch, bilateral

Automatic Temperature Stepdown

The temperature setting automatically lowers from High to Medium after 45 minutes of continuous use. See Figure 93 and Figure 94 at the end of this chapter. This circuit consists of:

- U6 24-stage digital logic frequency divider
- Two gates of U4 inverter
- R14 timing setup potentiometer

Alarm Drive Circuits

The over-temperature alarm drive circuit consists of:

- U7B comparator
- U8 optocoupler (senses the status of the temperature limit thermostats)
- Q1 FET

- SPKR1 speaker
- U12 dual timer
- Q6 FET
- D8 warning LED

The power fail alarm drive circuit consists of:

- U14 logical AND gate
- U13 dual timer power start indicator
- Q7 FET
- D8 warning LED
- U12 dual timer
- Q5 FET
- SPKR1 speaker

Temperature Control Circuit

The temperature control circuit consists of:

- U7 comparator
- K1 solid state relay

See *Output Temperature Check* procedure on page 31.

LCD Hour Meter

The warming system is equipped with an hour meter that is located on the front cover. The meter displays the number of hours the warming system has been in use. See Figure 92.



Figure 92. Hour Meter

AC Power Section

The warming system operates from a 100 - 120 VAC power source. Input power selection consists of a circuit breaker/rocker switch located on the front of the warming system and a line filter/power cord receptacle located at the bottom of the warming system. Power enters the main circuit board at J2, pins 3 and 4. The input voltage drives three major sections of the warming system:

- DC power supply
- heater
- blower

Blower

The blower is connected to the main circuit board through connector J2, pins 6, 7 and 9.

Heater

The heater section consists of a heater element (1,000 Watts) and an over-temperature thermostat that will open if the blower fails to operate.

Thermostat Protection

There are two thermostats (A and B) located at the exit of the blower. Thermostats A and B are redundant systems and, if necessary, will automatically turn the heater off when the output temperature exceeds a set level. This condition lights the Warning light on the control panel, and turns on an audible alarm. Refer to *Thermostat Protection Check* on page 28.

Over-Temperature Test Port

The over-temperature test port is located on the rear panel of the warming unit. The test port is used to verify the thermostat protection circuitry. Refer to *Thermostat Protection Check* on page 28.

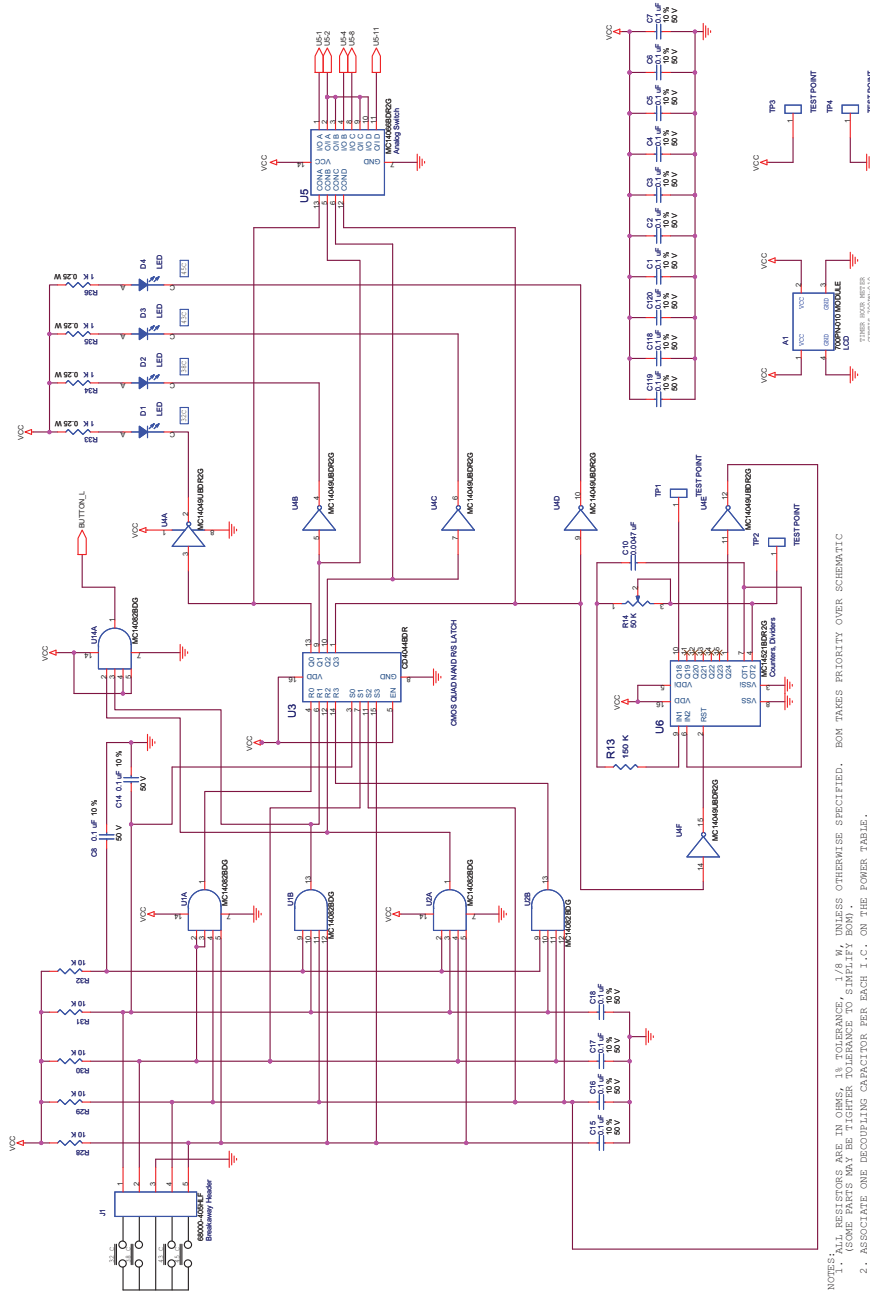

NOTES: ALL RESISTORS ARE IN OHMS, 1% TOLERANCE, 1/8 W, UNLESS OTHERWISE SPECIFIED. BOM TAKES PRIORITY OVER SCHEMATIC.
 1. SOME PARTS MAY BE TIGHTER TOLERANCE TO SIMPLIFY BOM.
 2. ASSOCIATE ONE DECOUPLING CAPACITOR PER EACH I.C. ON THE POWER TABLE.
 3. REFER TO POWER TABLE FOR VCC AND GND CONNECTIONS TO I.C.'S.

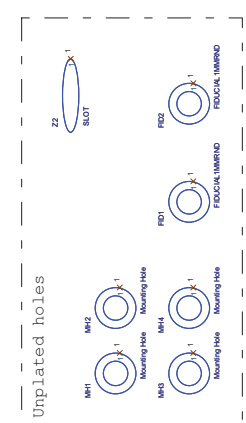
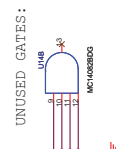

Control PCB GR100307

TEM_10095_A

Figure 93. Warming Unit Schematic (Sheet 1)

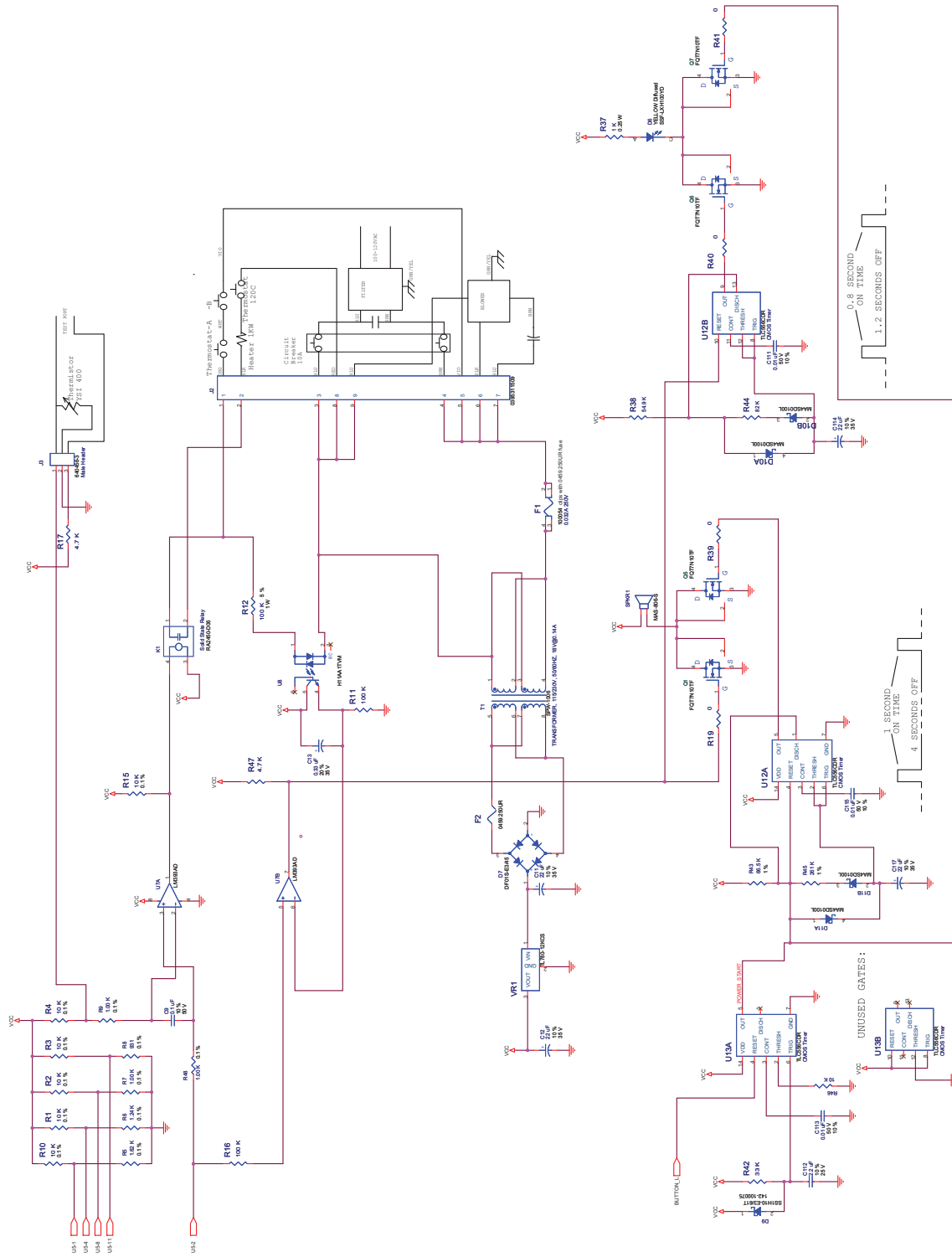

Figure 94. Warming Unit Schematic (Sheet 2)

Control PCB GR100307

TEM_10096_A

Index

A

AC power section, 105
Accessories web address, 90
Automatic shutdown, 14

B

Background information, 13
Blower, 105
Burn hazard, 10

C

Cleaning, 26
Control logic circuit, 103
Control PCBA Replacement, 50
Customized warming therapy, 14

D

DC power supply circuit, 102
Disinfecting, 26
Duct adapter assembly replacement, 67

E

Earth leakage current test, 34
Electric shock, 10
Electrical shock hazard, 10
Electromagnetic compatibility (EMC), 97
Electromagnetic emissions, 97
Electromagnetic immunity, 97
Enclosure leakage current test, 34
Explosion hazard, 9

F

Filter cover assembly replacement, 36
Fire hazard, 10

Front and rear covers, rejoining, 41
Front and rear covers, separating, 38
Front cover assembly replacement, 42

G

Ground integrity test, 34
Ground stud, 33

H

Heater, 106
Heater assembly replacement, 54
HEPA filter, 23
HEPA filter replacement, 21
Hose replacement, 65

I

Intended use, 13

L

LCD hour meter, 105

M

Main circuit board, 102
Manual availability, 13
Manufacturer's declaration, 96
MRI warning, 11

N

Nozzle replacement, 25

O

Operating hours meter, 22
Ordering information, 87, 95
Output temperature check, 31
Over-temperature test port, 106

P

Patient burns, 10
Possible explosion hazard, 9
Possible patient injury, 30
Power cord replacement, 24
Power cord routing, 24, 37, 39
Power fail / start alarm check, 27

R

Rear cover assembly replacement, 72
Repacking, different carton, 93
Repacking, original carton, 91
Replacement parts web address, 90
Returned goods authorization (RGA) number, 91
Returning the WT-5300A, 91

S

Safety features, 14

Safety information, 9, 13, 21, 27, 87, 91, 95, 101

Safety tests, 33

Single patient use, 10

Specifications

earth leakage current, 100

enclosure leakage current, 100

general, 95

ground integrity, 99

Surface cleaning, 26

T

Temperature control circuit, 104

Thermostat protection, 106

Thermostat protection check, 28

W

Warning light, 15

Warnings, 9, 13, 28, 35, 87, 96, 103



Tyco Healthcare Group LP
Nellcor Puritan Bennett LLC
4280 Hacienda Drive
Pleasanton, CA 94588 USA
Toll Free: 1.800.635.5267

Authorized Representative
Tyco Healthcare UK LTD
154 Fareham Road
Gosport PO13 0AS, U.K.

© 2011 Nellcor Puritan Bennett LLC
All rights reserved.



Manufactured in the U.S.A.
10066999 Rev A 08/2011

tyco

Healthcare